

400/640 LC4-E, 640 LC4-E SUPERMOTO, 640 LC4 ADVENTURE, 640 DUKE

KTM
SPORTMOTORCYCLES

ERSATZTEILKATALOG
MOTOR

SPARE PARTS MANUAL
ENGINE

2001

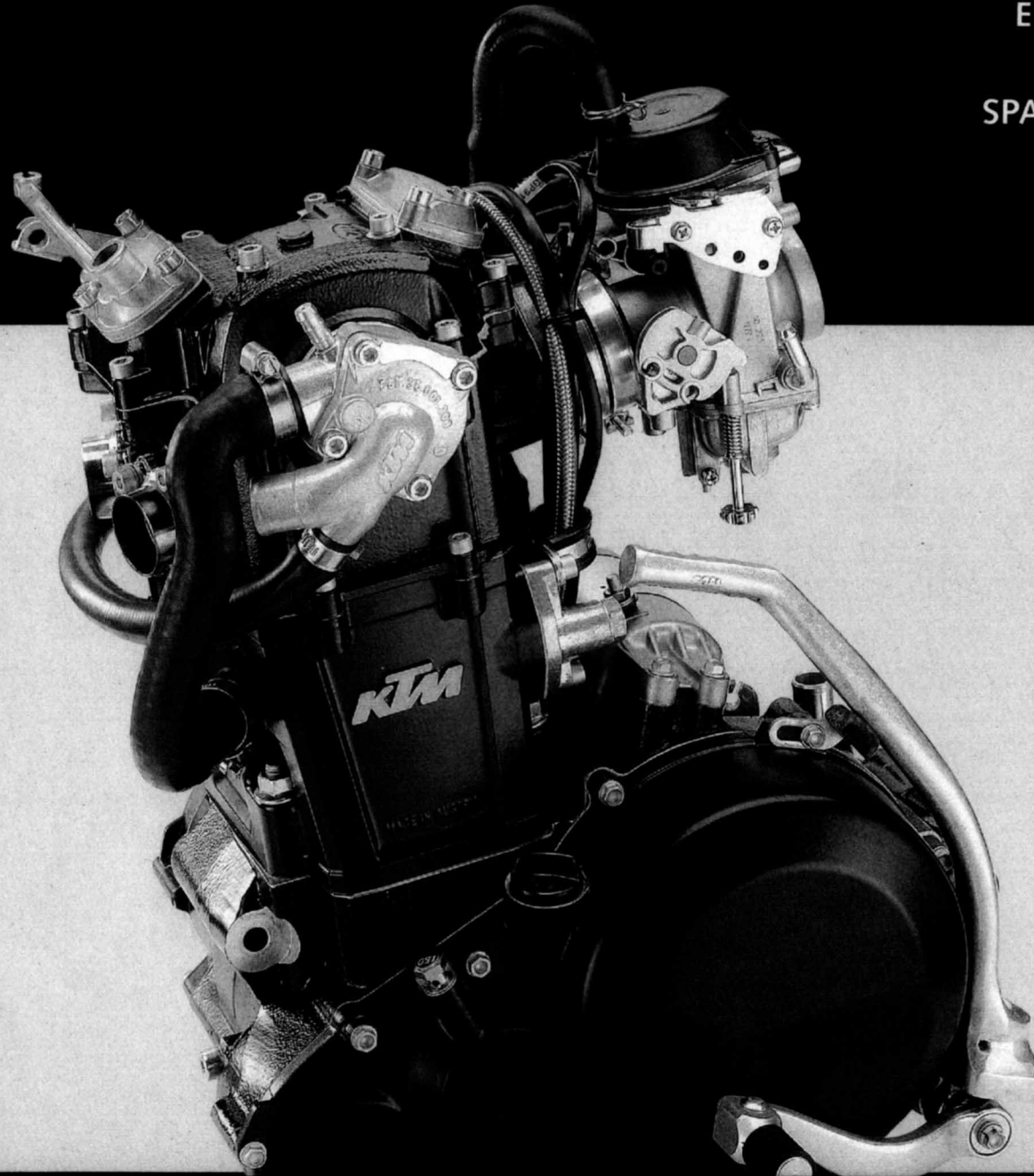

MOTORGEHÄUSE
ENGINE CASE

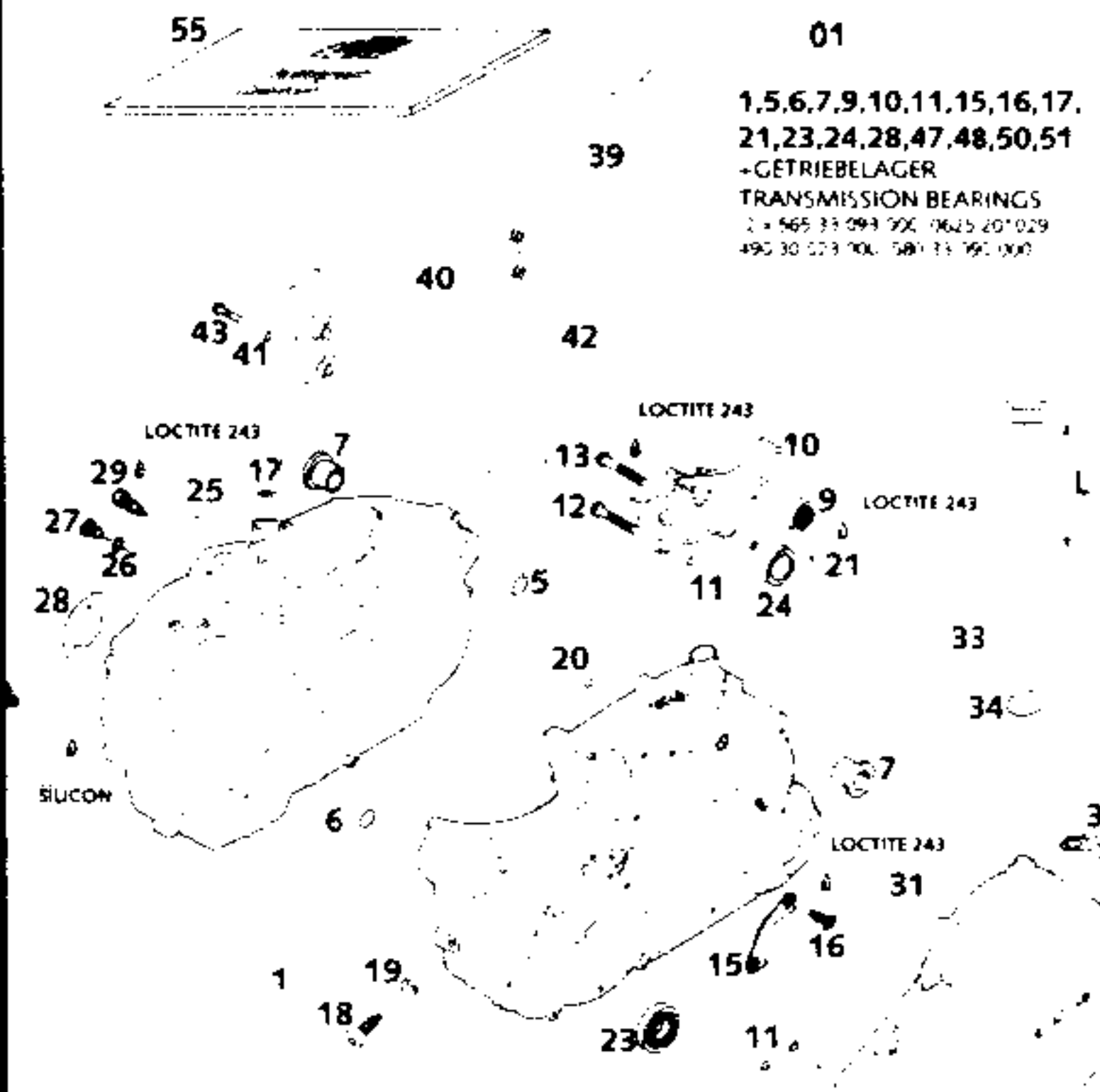

SEITE
Page
3

KURBELWELLE, KOLBEN
CRANKSHAFT, PISTON

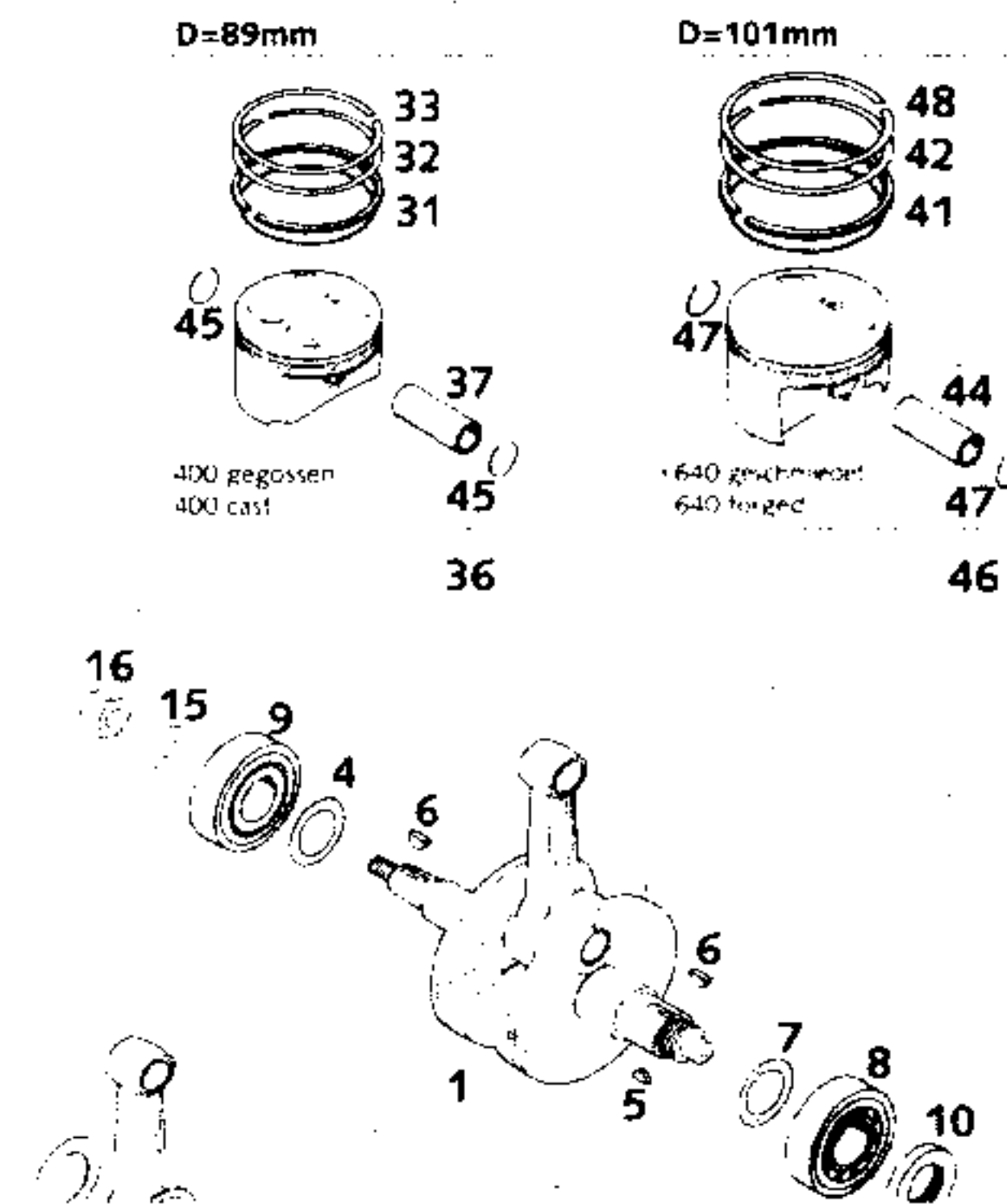

SEITE
Page
5

AUSGLEICHSWELLE
BALANCER SHAFT

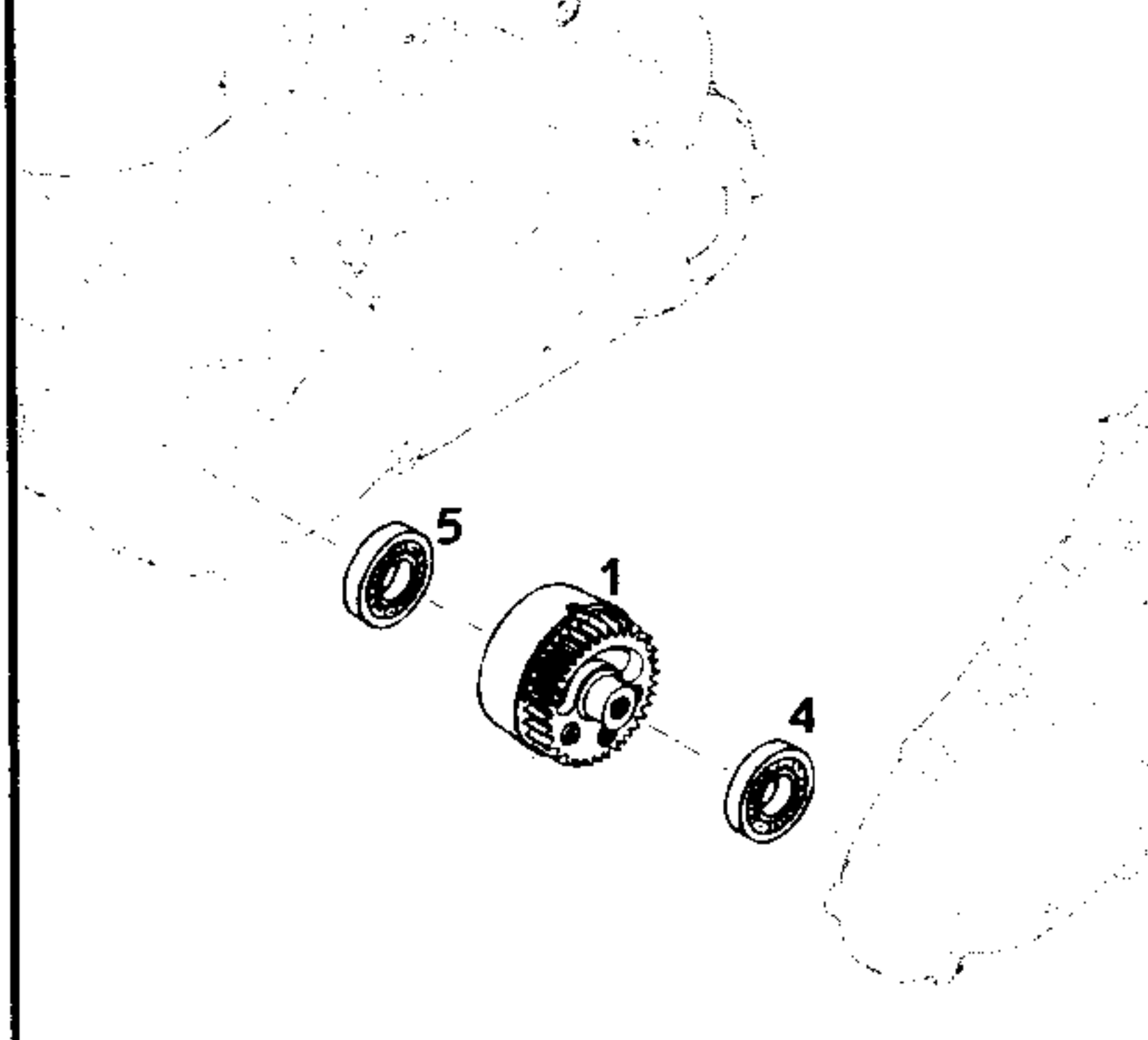

SEITE
Page
6

ZYLINDER
CYLINDER

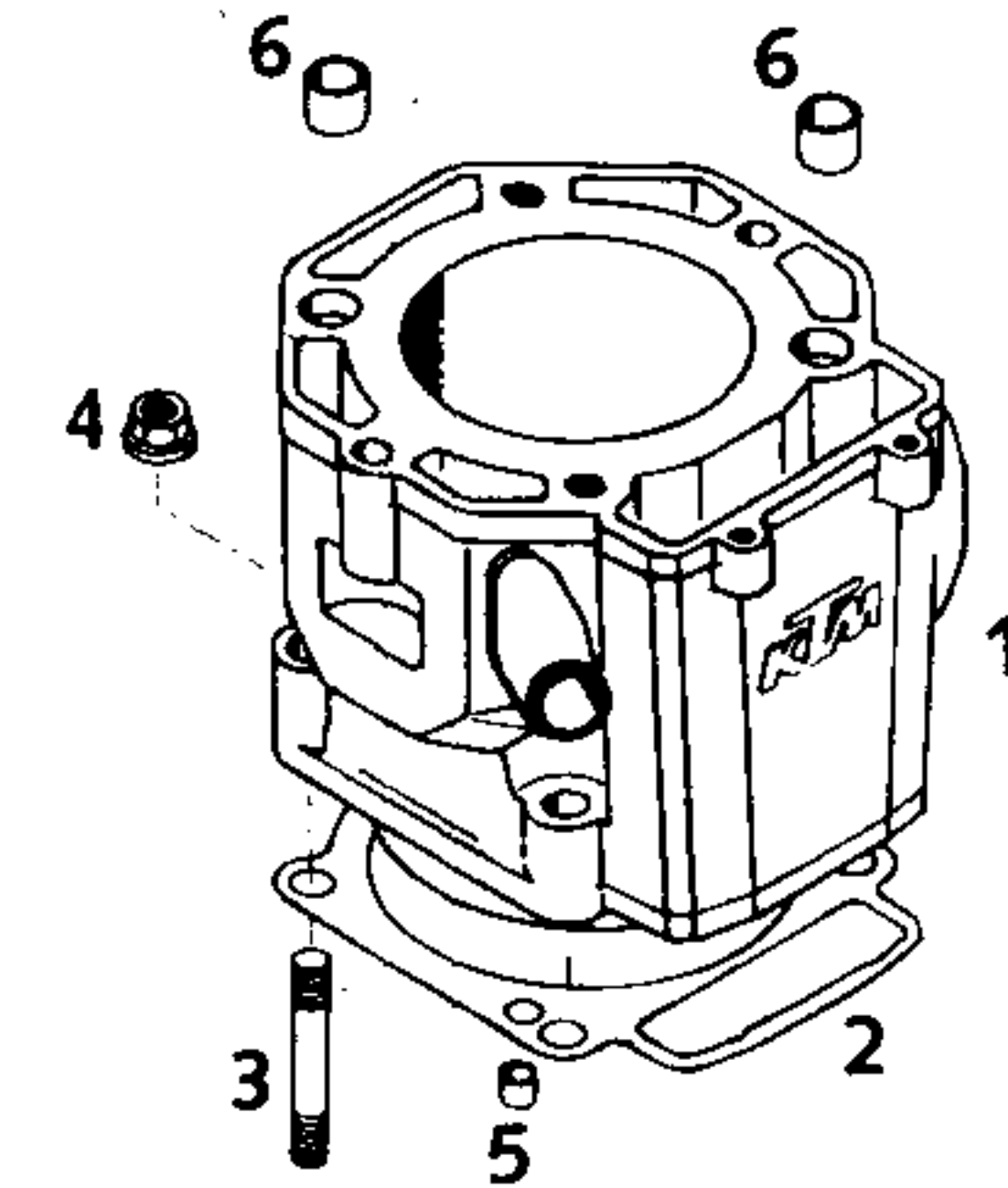

SEITE
Page
7

ZYLINDERKOPF
CYLINDER HEAD

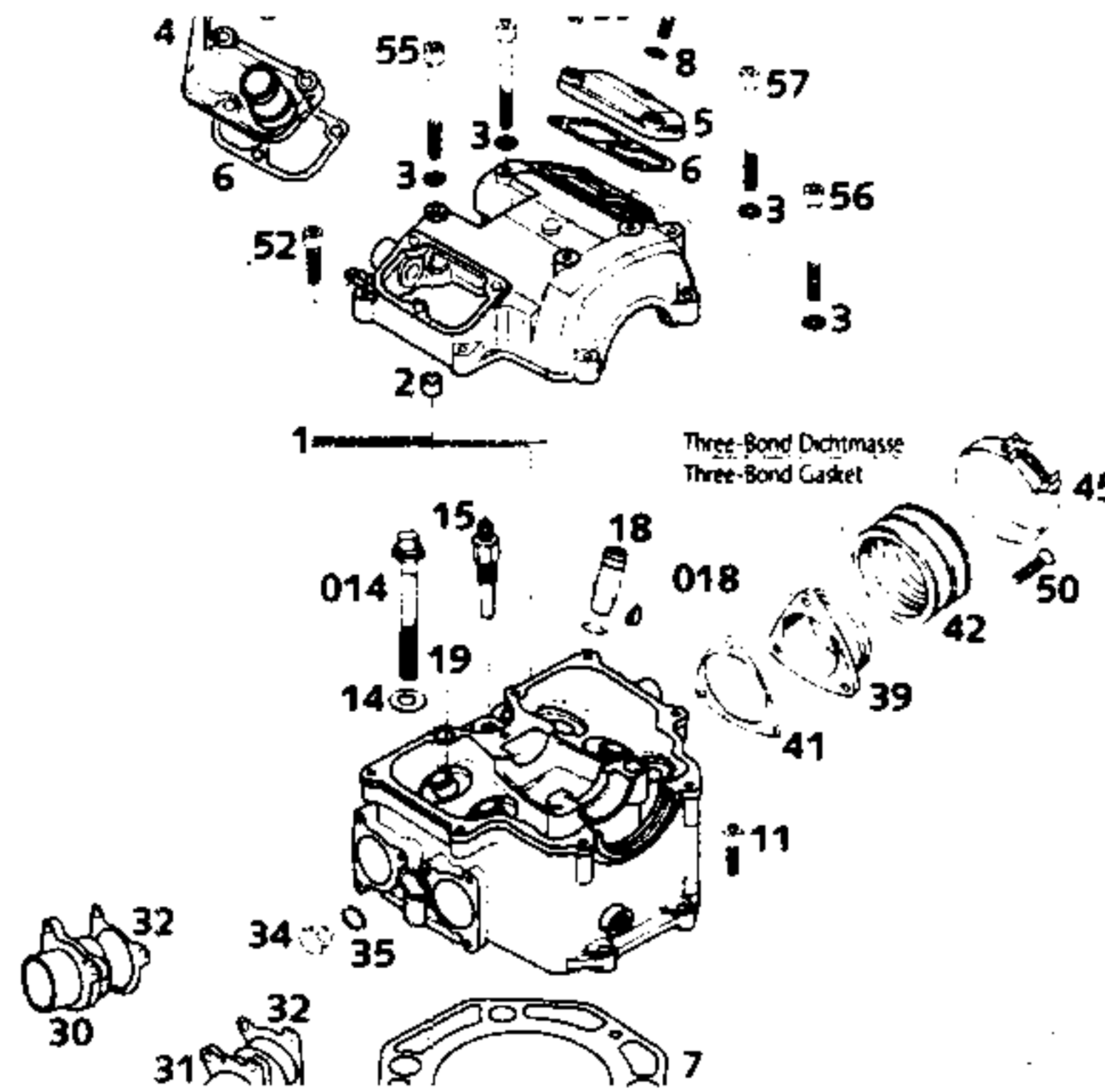

SEITE
Page
8

SEJUNDÄRLUFTSYSTEM
SECONDARY AIR SYSTEM

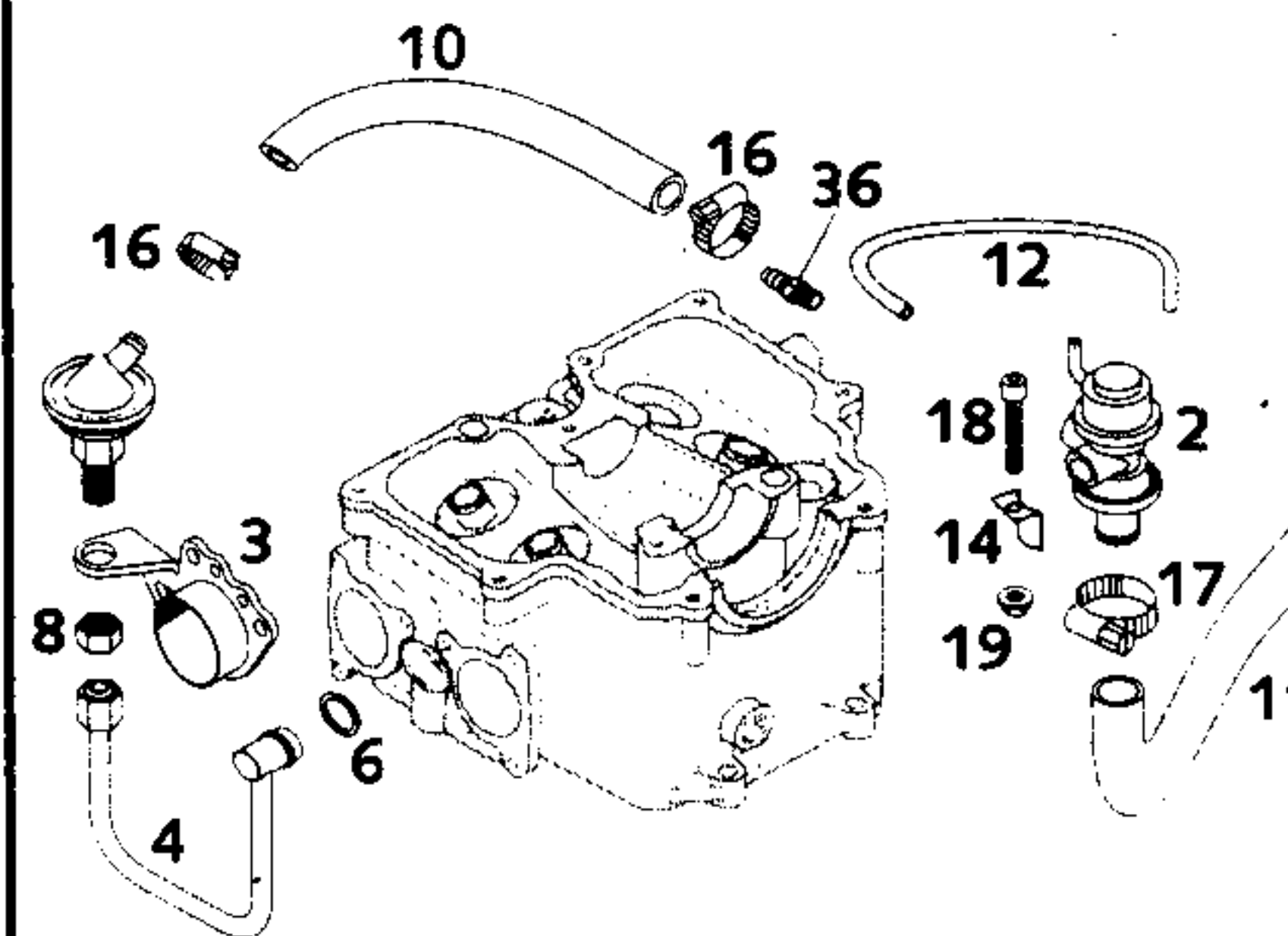

SEITE
Page
10

VENTILTRIEB
VALVE DRIVE

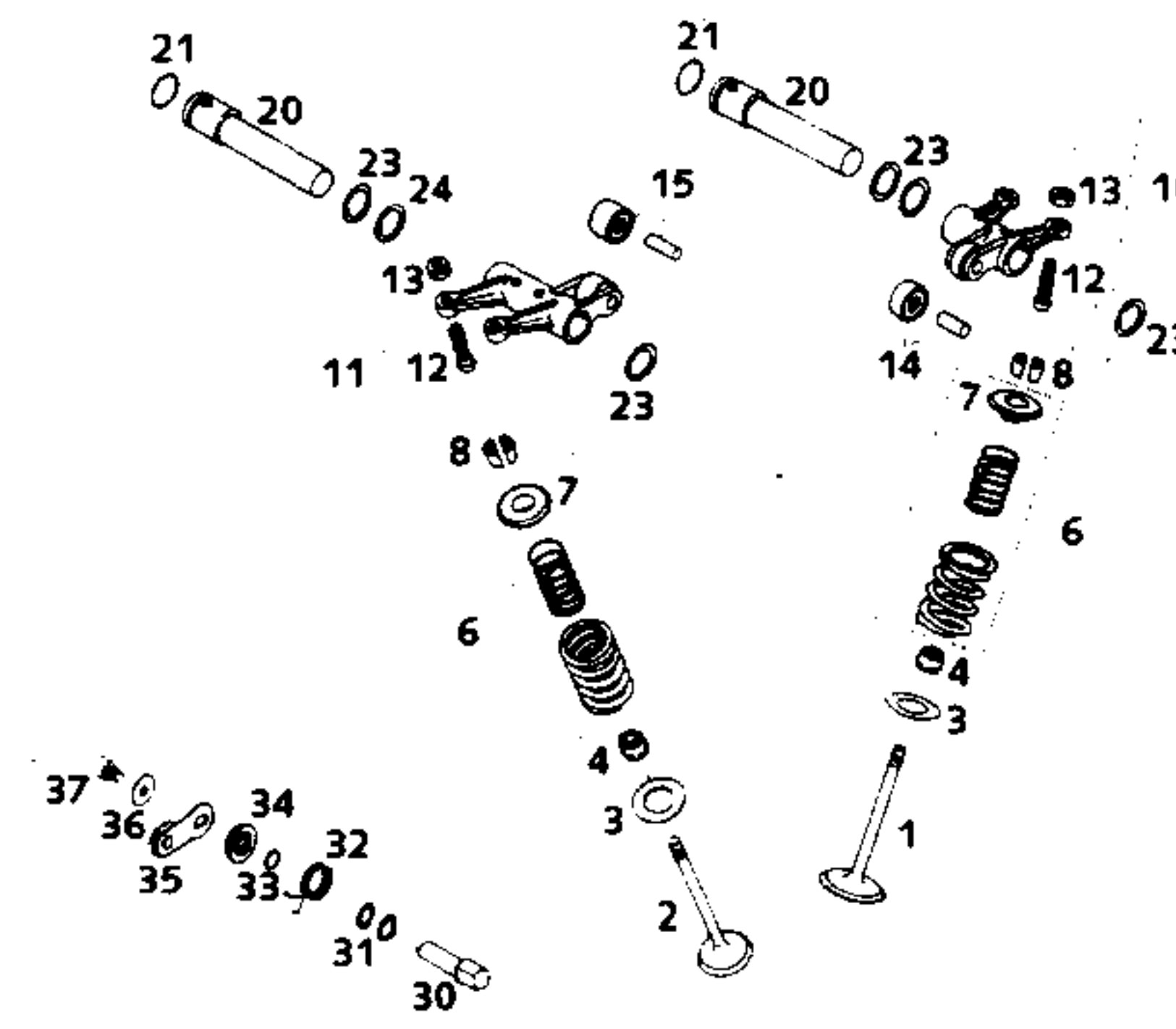

SEITE
Page
11

STEUERTRIEB
TIMING VALVE

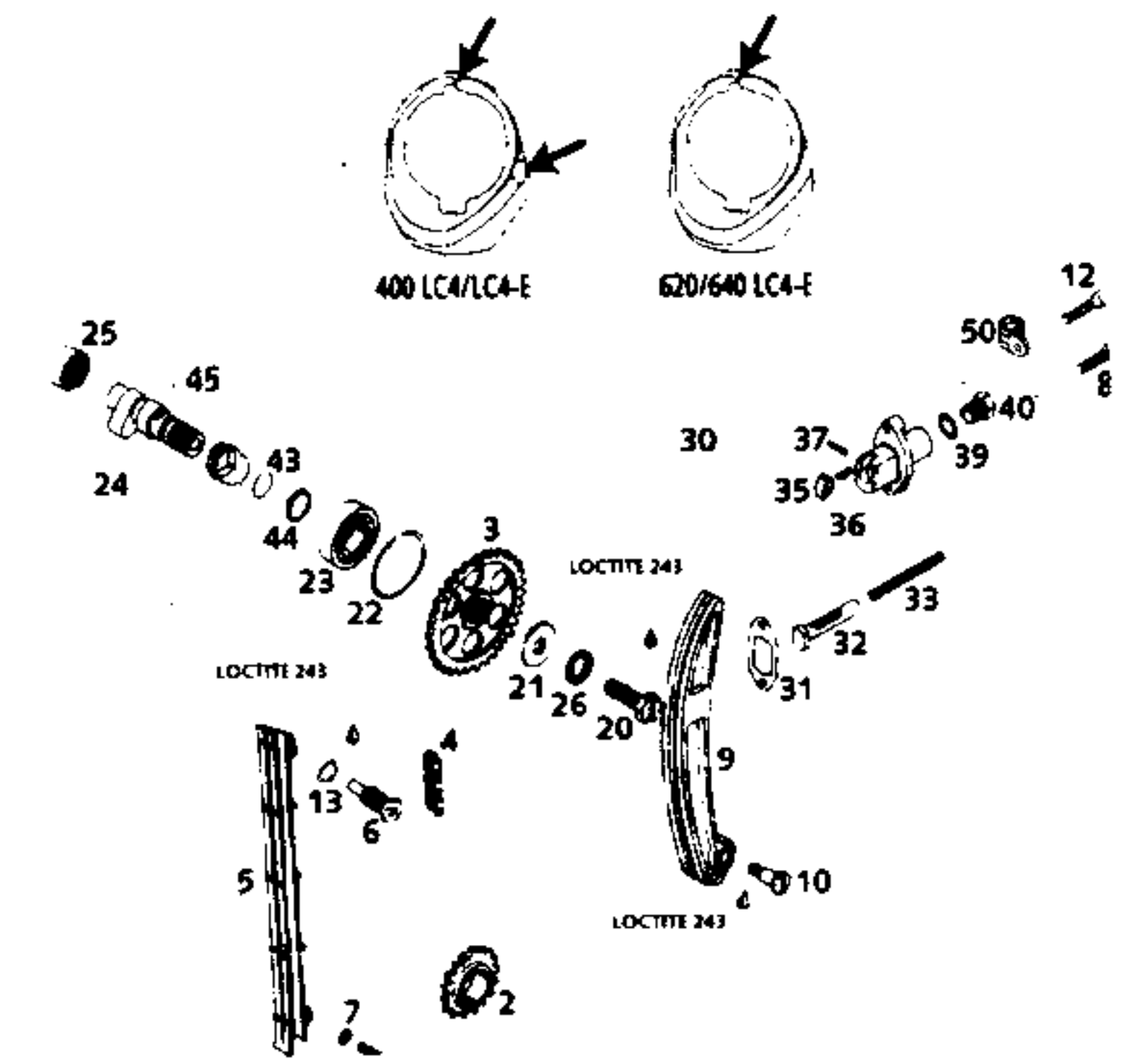

SEITE
Page
12

SCHMIERSYSTEM
LUBRICATING SYSTEM

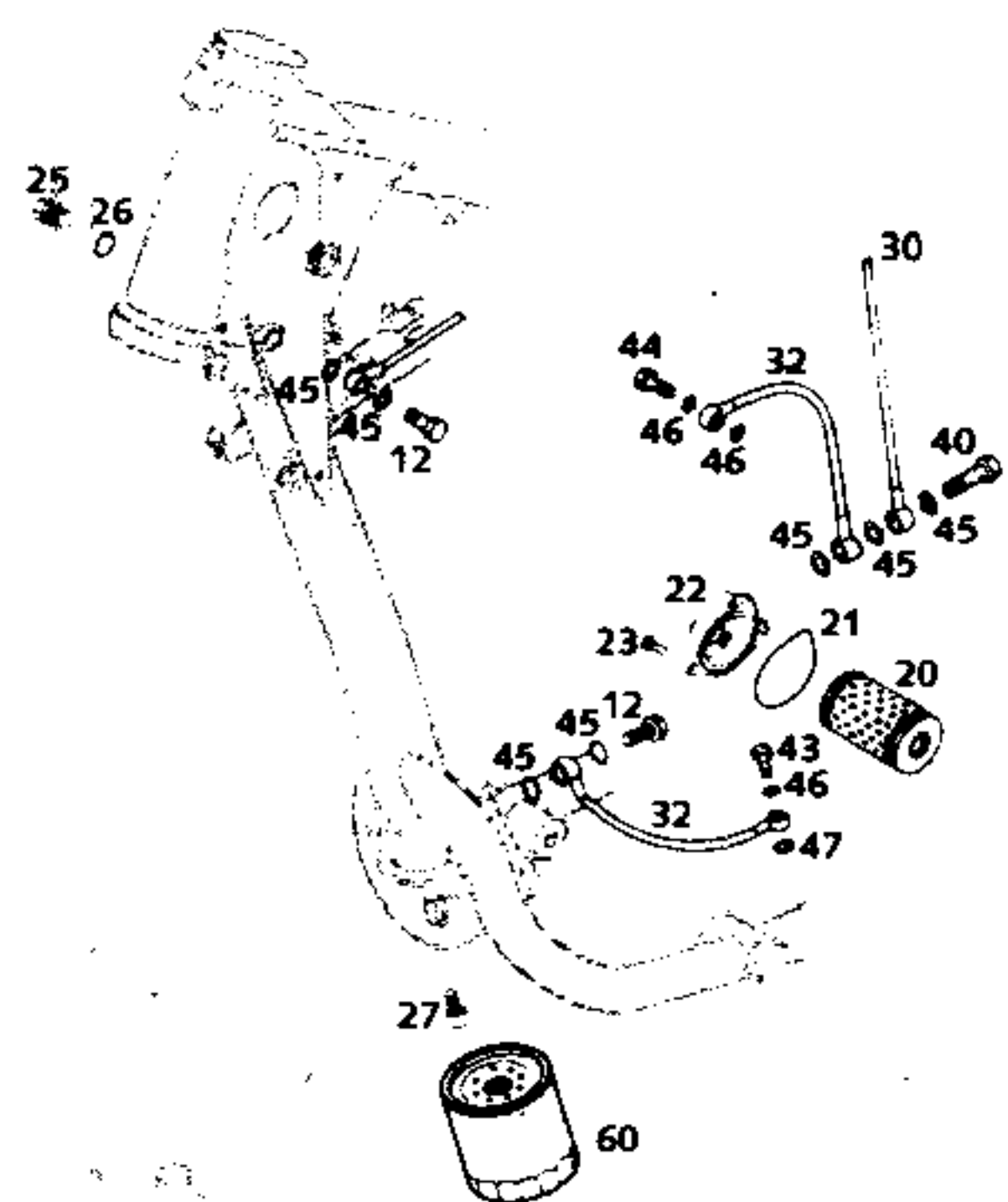

SEITE
Page
14

MOTORENTLÜFTUNG
BREATHING SYSTEM

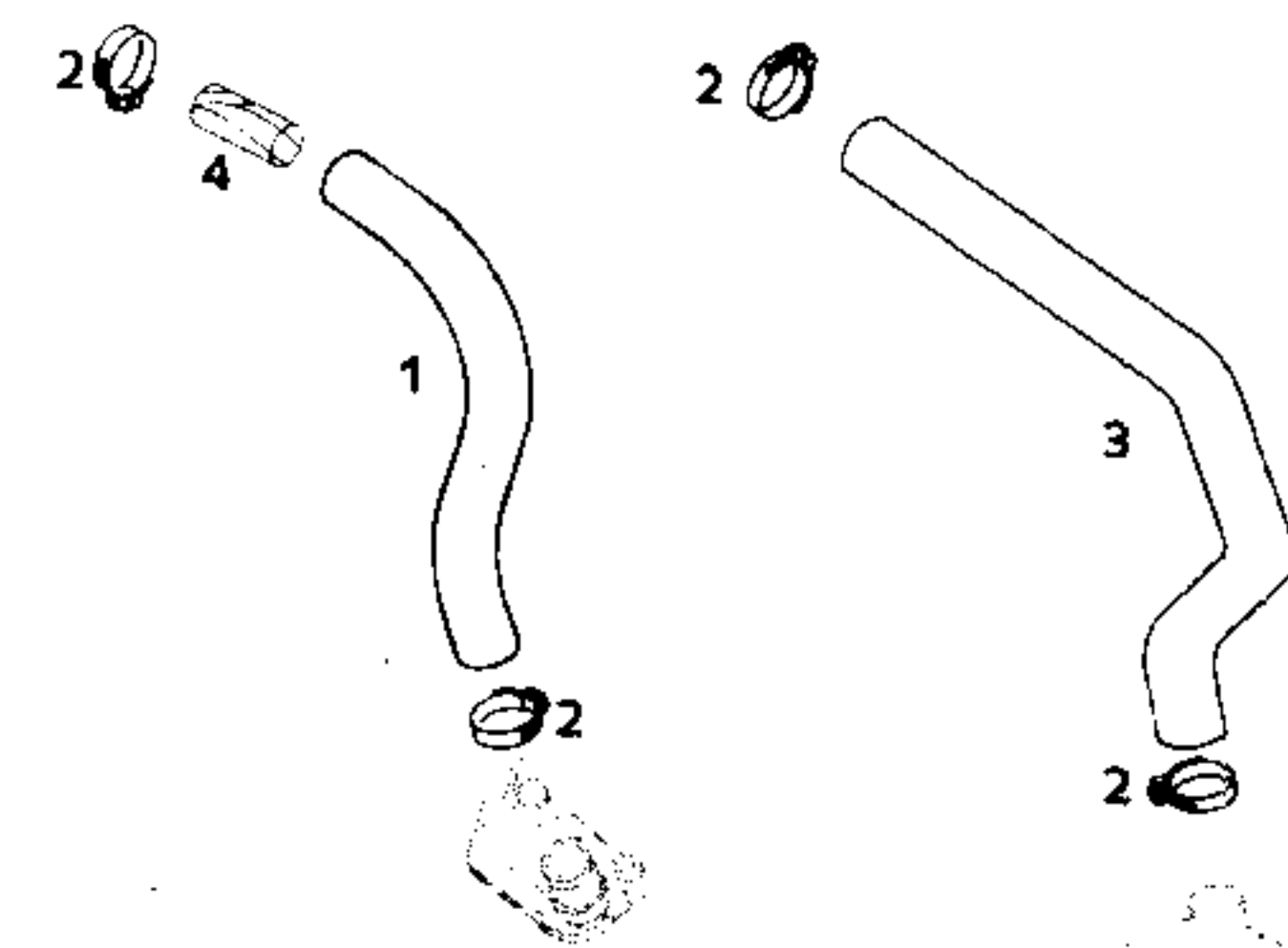

SEITE
Page
15

VERGASER DELL ORTO PHM 38 ND
CARBURETOR DELL ORTO PHM 38 ND

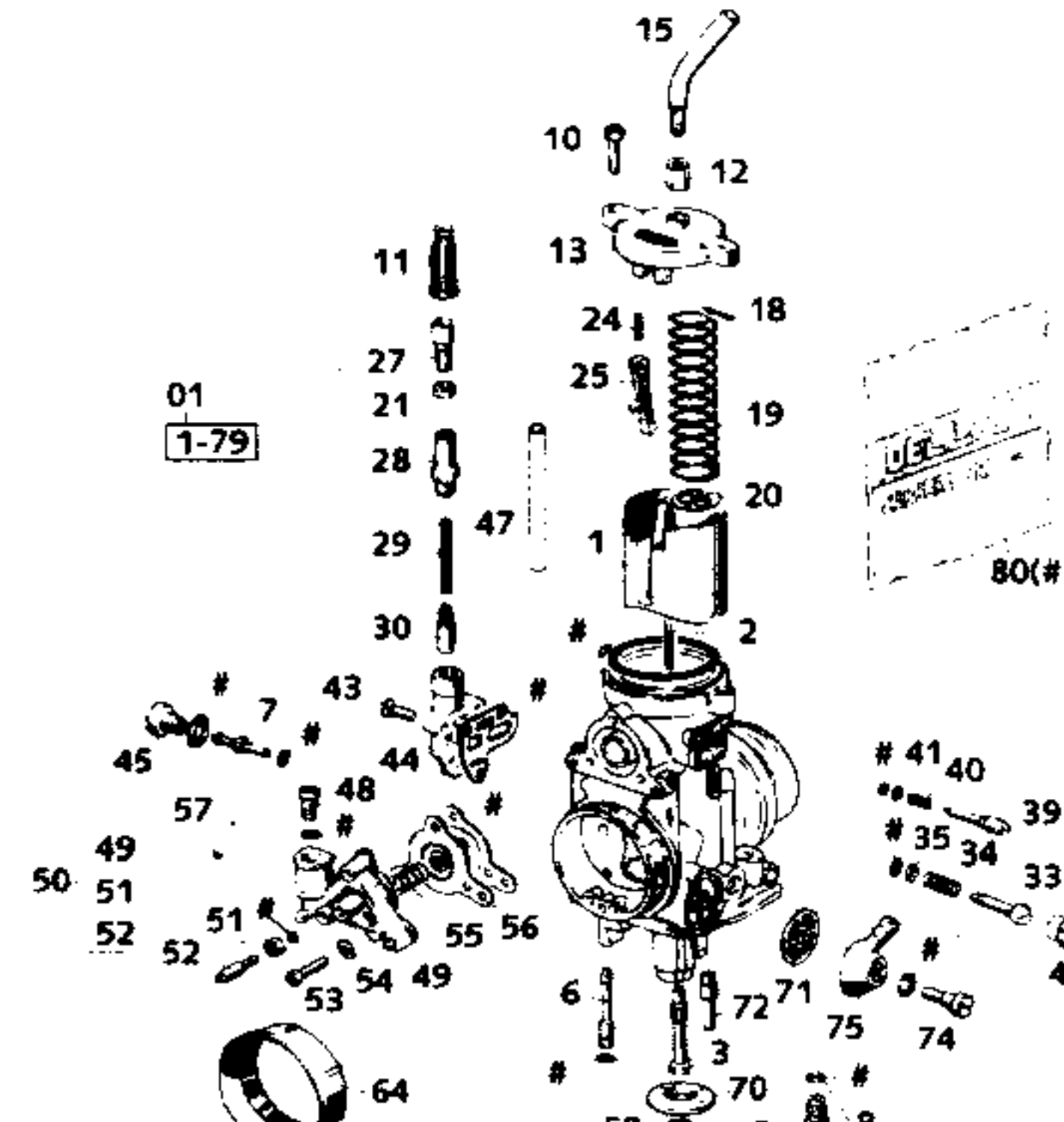

SEITE
Page
16

VERGASER MIKUNI BST 40
CARBURETOR MIKUNI BST 40

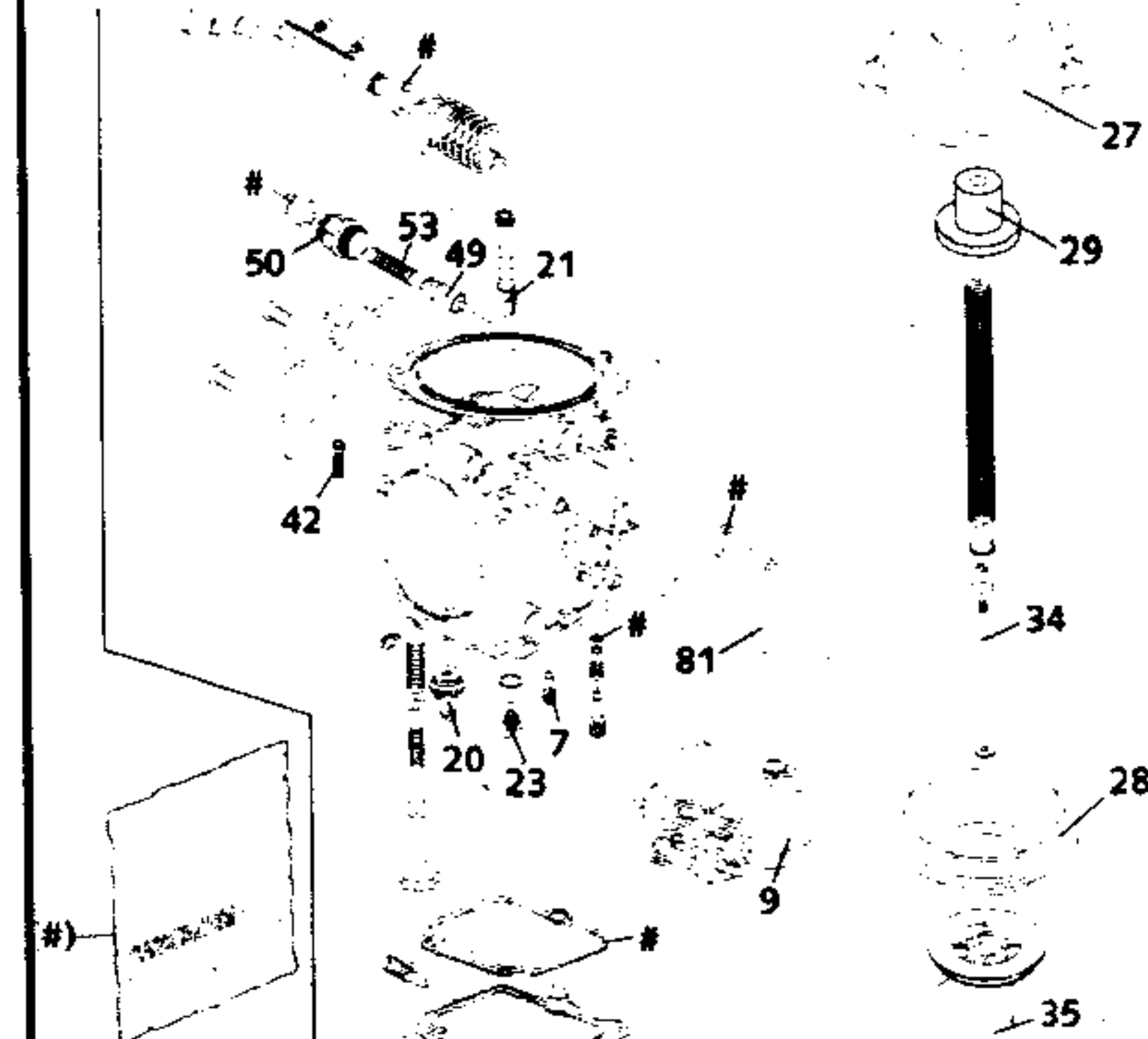

SEITE
Page
18

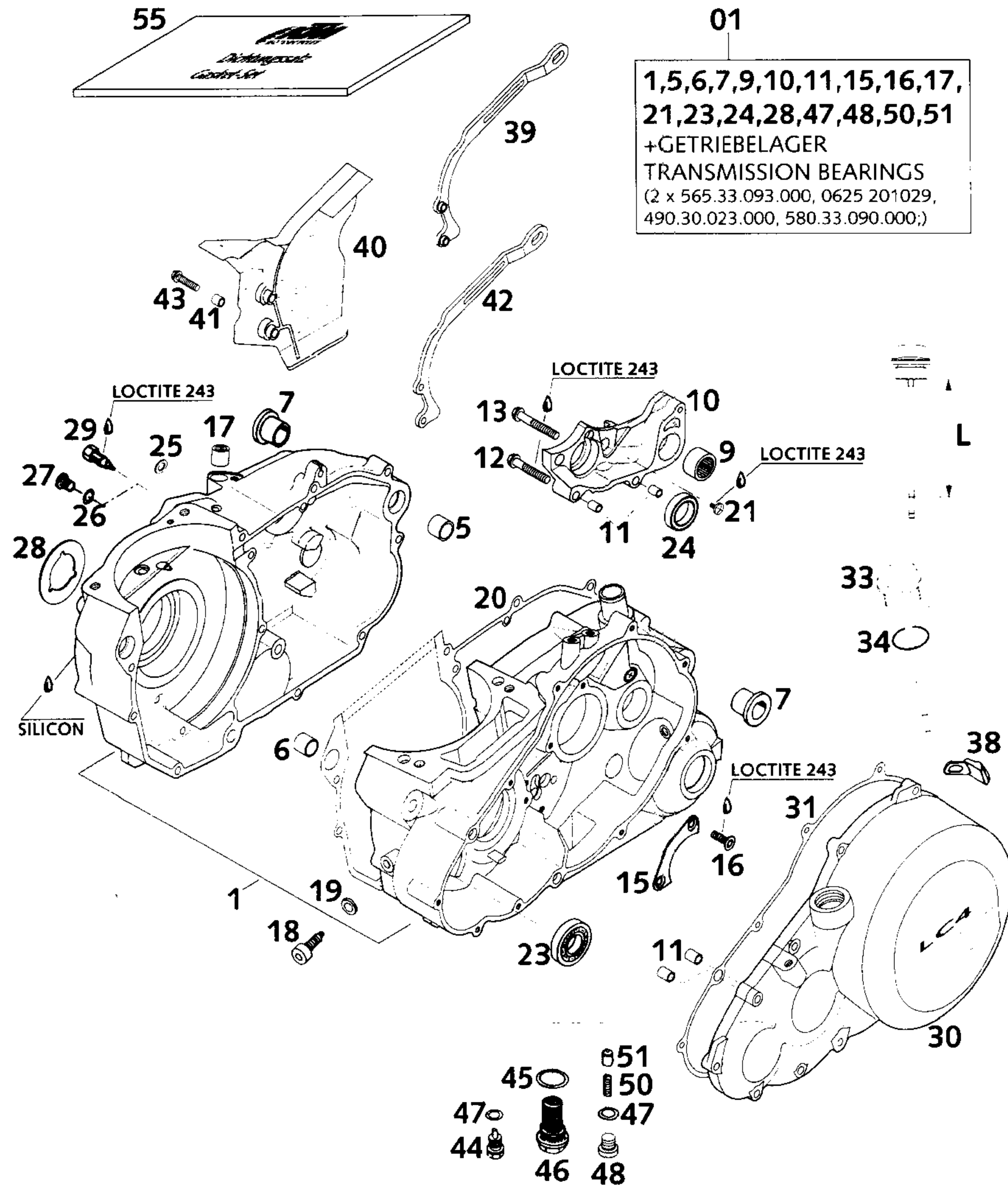

FIG	TEILNR/PARTNR	BEZEICHNUNG	DESCRIPTION	QTY
01	584.30.000.144/30	MOTORGEH. KPL.M.GETR.LAG. 2000 SCHWARZ	ENGINE CASE CPL.W.TR.BEAR 2000 BLACK	1
5	501.30.027.000	PASSHÜLSE 19 X15,1X12	DOWEL 19 X15,1X12	1
6	510.30.026.100	PASSHÜLSE 17 X14 X12	DOWEL 17 X14 X12	1
7	501.30.010.000	GEHÄUSEBÜCHSE	CRANK CASE BUSH	2
9	580.33.097.000	NADELLAGER HK 2216 KSE	NEEDLE BEARING HK 2216 KSE	1
10	583.30.011.000	SCHALTUNGSTRÄGER LC4'94	SHIFT MECHANISM SUPPORT LC4'94	1
11	490.30.090.000	PASSHÜLSE 9,8 X 7 X 10	DOWEL 9,8 X 7 X 10	4
12	0015 060353	SK.BUNDSCHRAUBE M 6X35 SW=8	HH COLLAR SCREW M 6X35 WS=8	1
13	0015 060403	SK.BUNDSCHRAUBE M 6X40 SW=8	HH COLLAR SCREW M 6X40 WS=8	1
15	565.30.017.000	HALTEBLECH	RETAINING BRACKET	1
16	0991 060163	SENKSCHRAUBE DIN7991-M 6X16	FLAT HEAD SCR. DIN7991-M 6X16	2
17	503.32.095.000	NADELLAGER HK 1212	NEEDLE BEARING HK 1212	2
18	580.30.080.000	FIXIERSCHRAUBE M8	LOCATING SCREW M8	1
19	580.30.081.000	CU-DICHTRING 8 X 14 X 3	CU-SEAL RING 8 X 14 X 3	1
20	584.30.039.000	GEHÄUSEDICHTUNG LC4-E '96	ENGINE CASE GASKET LC4-E '96	1
21	0985 050103	LINSENSCHRAUBE DIN7985-M 5X10	OVAL HEAD SCR. DIN7985-M 5X10	1
23	0625 160030	RILLENKUGELLAGER 16003 C3	GROOVED BALL BEARING 16003 C3	1
24	0625 618050	RILLENKUGELLAGER 61805 C3	BALL BEARING 61805 C3	1
25	0603 061001	CU-DICHTRING DIN7603- 6X10X1	CU-SEAL RING DIN7603- 6X10X1	1
26	580.38.032.010	CU-DICHTRING DIN7603-10X14X1	CU-SEAL RING DIN7603-10X14X1	X
27	490.30.029.000	ÖLABLASSSCHRAUBE ISK-M10X10	OIL DRAIN PLUG ISK-M10X10	X
28	584.40.091.000	ANLAUFSCHIEBE 33 X 58 X 1,5	STOP DISK 33 X 58 X 1,5	1
29	580.11.081.100	KONTAKTSCHRAUBE M10 STAHL '98	CONTACT SCREW M10 STEEL '98	1
30	583.30.101.100	KUPPLUNGSDECKEL LC4 SCHWARZ '99	CLUTCH COVER CPL.BLA."LC4"2000	1
31	583.30.025.000	KUPPLUNGSDECKELDICHTUNG '94	CLUTCH COVER GASKET '94	1
33	583.30.020.144	ÖLMESSTAB KPL. L=93MM '96	OIL DIPSTICK CPL. L=93MM '96	1
34	0770 160030	O-RING 16,00X3,00 NBR 70	O-RING 16,00X3,00 NBR 70	1
38	583.33.041.000	ANSCHLAGGUMMI	BUMP RUBBER	1
39	587.30.047.000	KETTENDÄMPFUNGSBL.17Z DUKE '99 NUR FÜR 640 DUKE	CHAIN DAMPER SHEET 17Z DUKE'99 ONLY FOR 640 DUKE	1
40	584.30.060.000	KETTENABDECKUNG SCHWARZ '96	SPROCKET COVER BLACK '96	1
41	546.13.038.150	BÜCHSE 6,5X8X11	BUSHING 6,5X8X11	2
42	584.30.047.000	KETTENDÄMPFUNGSBL.17Z LC4-E	CHAIN DAMPERSHEET 17T LC4-E	X
42	584.30.047.100	KETTENDÄMPFUNGSBL.15/16Z LC4-E	CHAIN DAMPERSHEET 15/16T LC4-E	1

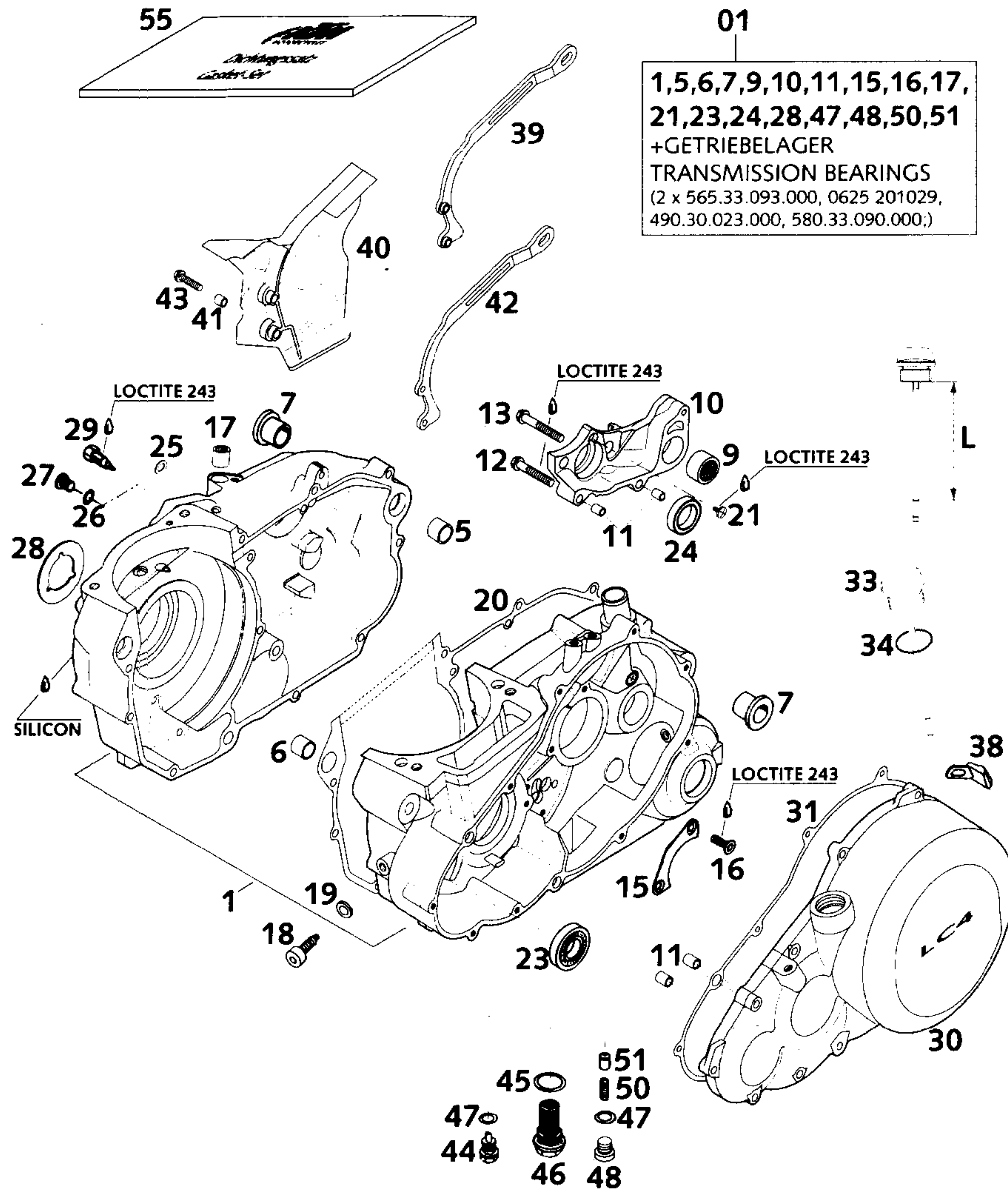
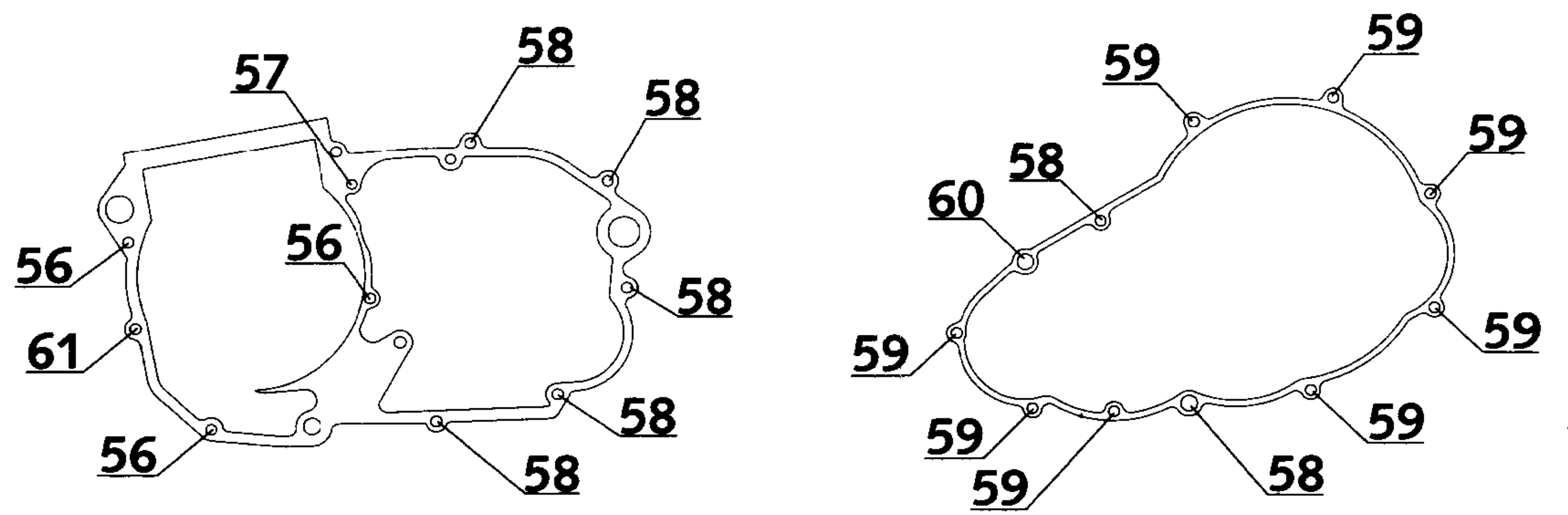
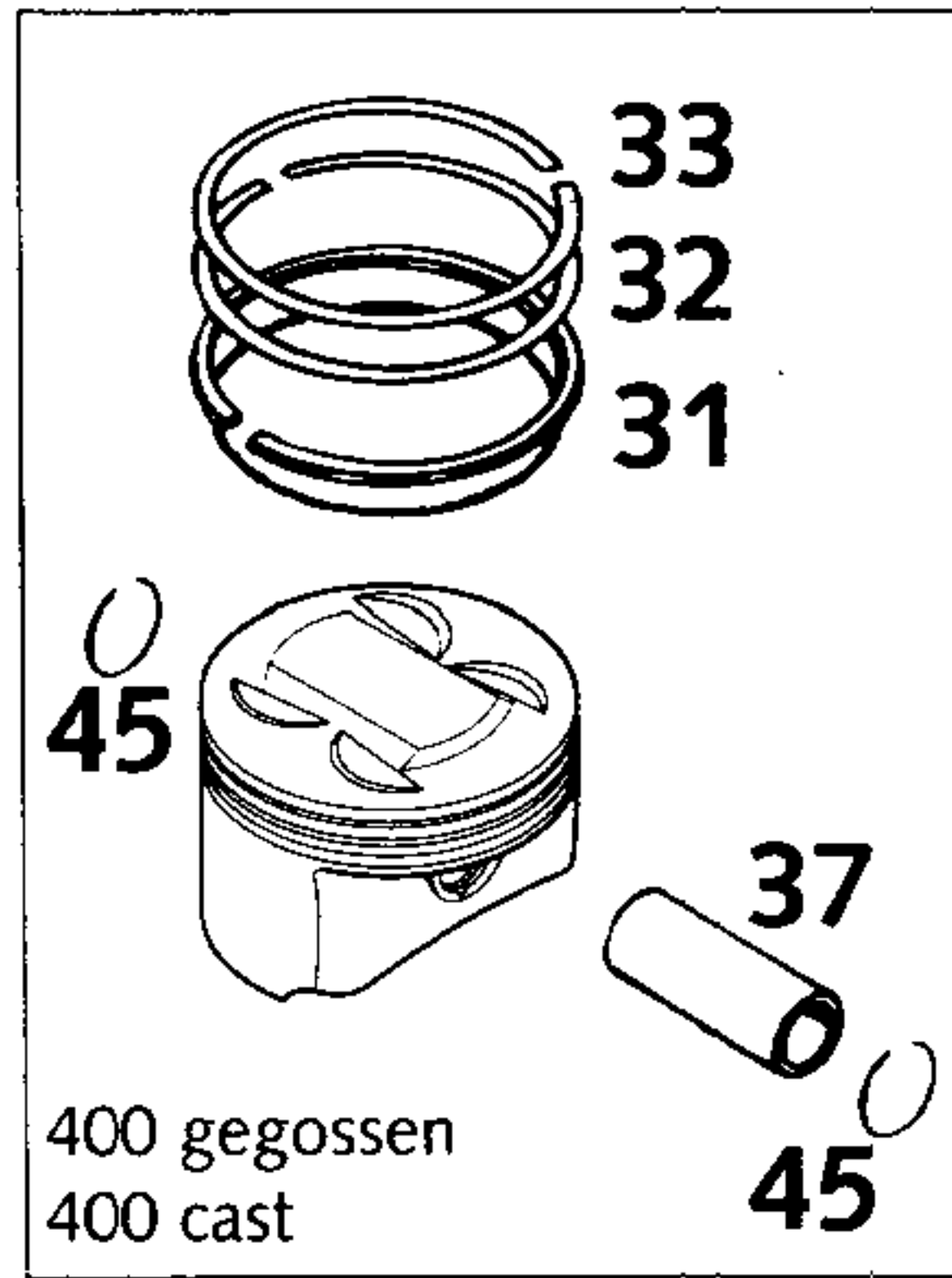

FIG	TEILNR/PARTNR	BEZEICHNUNG	DESCRIPTION	QTY
43	0015 060253	SK.BUNDSCHRAUBE M 6X25 SW=8	HH COLLAR SCREW M 6X25 WS=8	2
44	580.30.021.000	ÖLABLASSCHR.B.M.MAGNET M12X1,5	OILDRAIN PLUG W.MAGNET M12X1,5	1
45	580.38.017.100	CU-DICHRING DIN7603-22X27X2	CU-SEAL RING DIN7603-22X27X2	1
46	580.38.019.100	ÖLVERSCHLUSSSCHRAUBE M22X1,5	OIL DRAIN PLUG M22X1,5	1
47	580.38.022.000	CU-DICHRING DIN7603-12X18X1,5	CU-SEAL RING DIN7603-12X18X1,5	2
48	0908 120153	VERSCHL.SCHR. DIN0908-M12X1,5	PLUG DIN0908-M12X1,5	1
50	580.38.023.300	DRUCKFEDER L=25MM D=1MM	PRESSURE SPRING L=25MM D=1MM	1
51	580.38.028.000	VENTILKOLBEN D=10MM	VALVE PISTON D=10MM	1
55	584.30.099.000	DICHTUNGSSATZ LC4-E '96	GASKET SET LC4-E '96	1
56	0015 060553	SK.BUNDSCHRAUBE M 6X55 SW=8	HH COLLAR SCREW M 6X55 WS=8	3
57	0015 060653	SK.BUNDSCHRAUBE M 6X65 SW=8	HH COLLAR SCREW M 6X65 WS=8	1
58	0015 060303	SK.BUNDSCHRAUBE M 6X30 SW=8	HH COLLAR SCREW M 6X30 WS=8	7
59	0015 060253	SK.BUNDSCHRAUBE M 6X25 SW=8	HH COLLAR SCREW M 6X25 WS=8	8
60*	0015 060403	SK.BUNDSCHRAUBE M 6X40 SW=8	HH COLLAR SCREW M 6X40 WS=8	1
61*	0015 060953	SK.BUNDSCHRAUBE M 6X95 SW=8	HH COLLAR SCREW M 6X95 WS=8	1



D=89mm



36

D=101mm

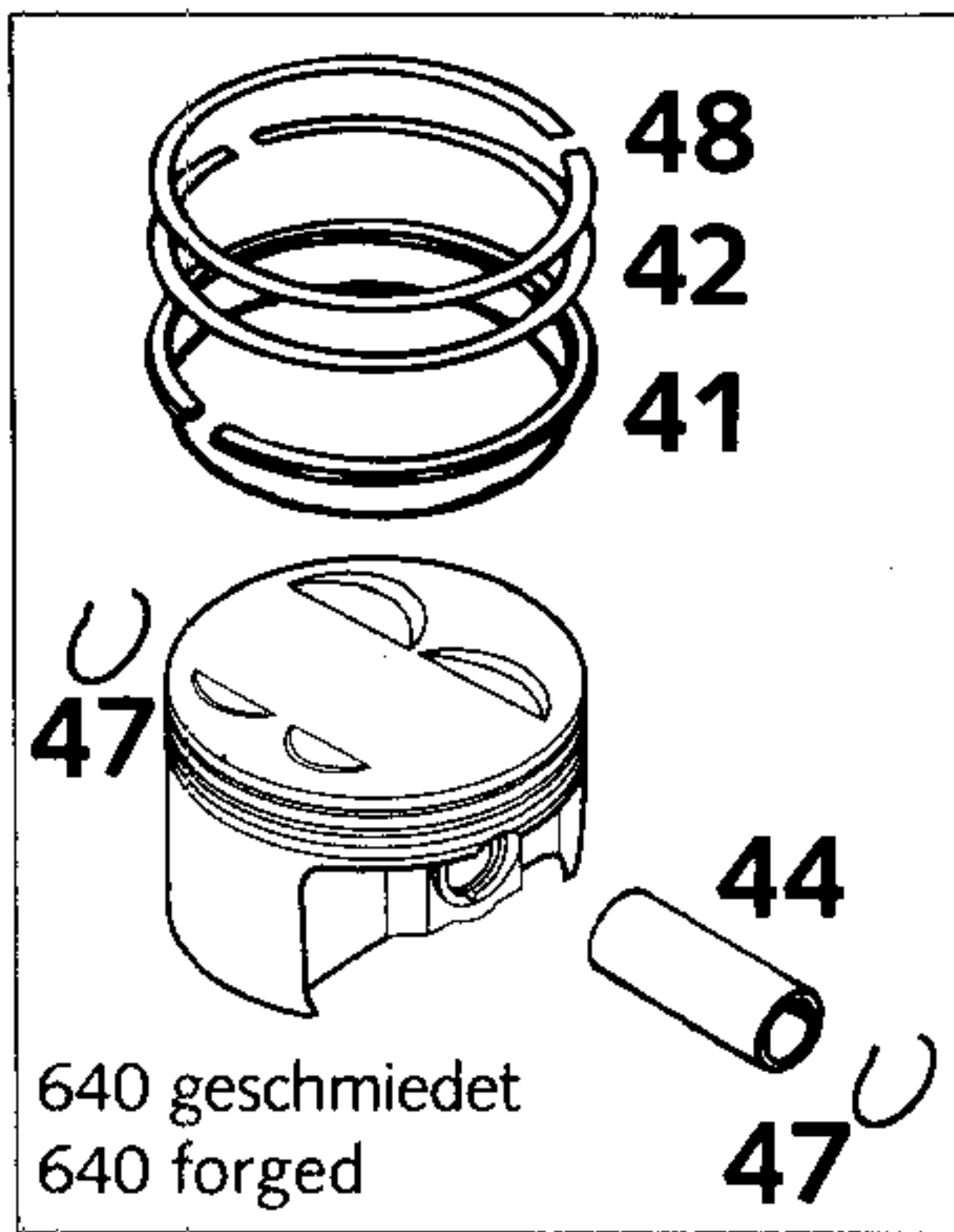

46

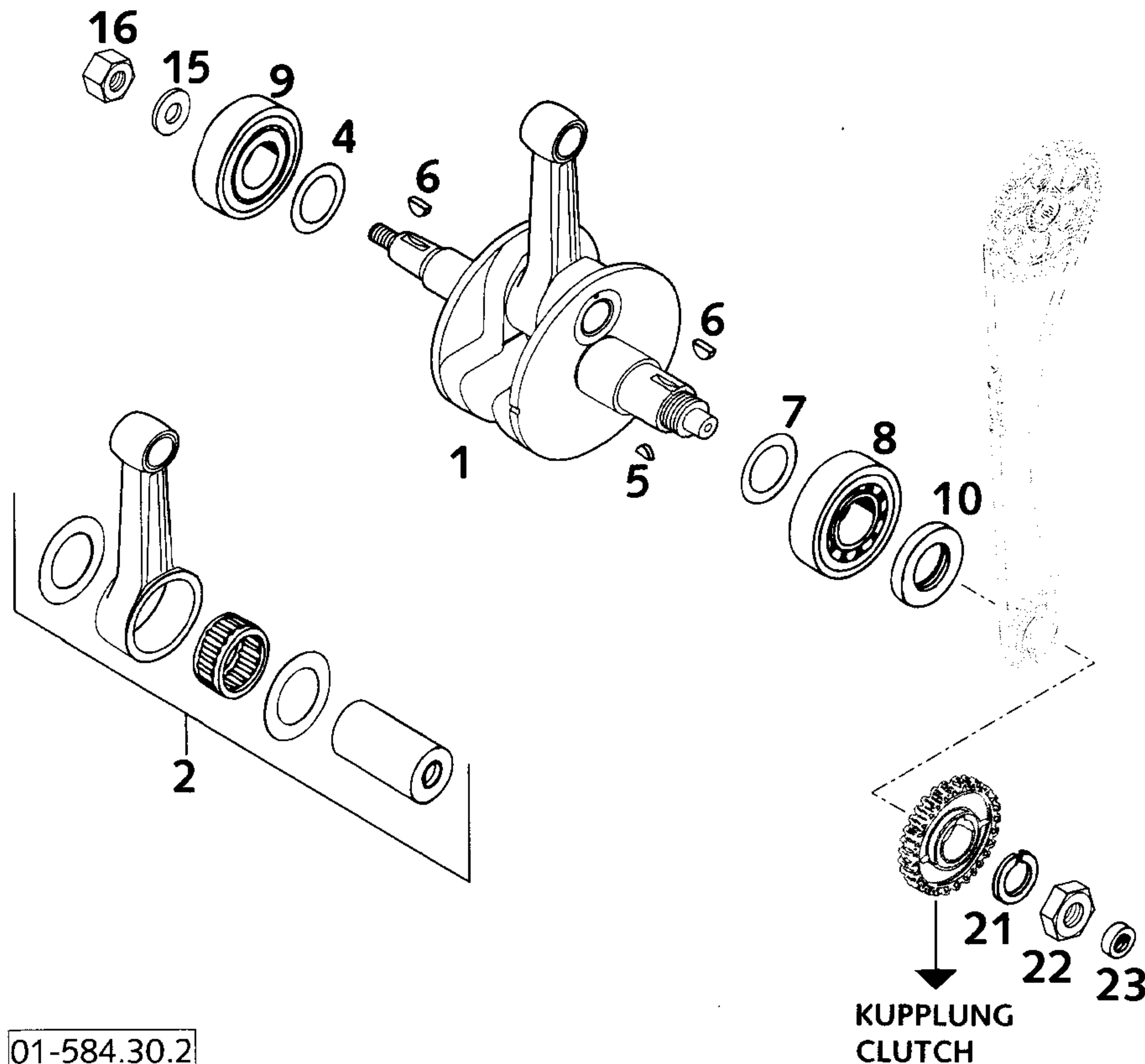

FIG	TEILNR/PARTNR	BEZEICHNUNG	DESCRIPTION	QTY
1	577.30.018.100	KURBELWELLE KPL. 400 LC4-E '97 HUB 64MM	CRANKSHAFT CPL. 400 LC4-E '97 STROKE 64MM	1
1	584.30.018.100	KURBELWELLE KPL. 640 LC4-E '98 HUB 78MM	CRANKSHAFT CPL. 640 LC4-E '98 STROKE 78MM	1
2	580.30.015.044	PLEUEL-REP.SATZ LC4 350/400/500/612 CCM L=140MM	CONNECTING ROD REPAIR SET LC4 350/400/500/612 CCM L=140MM	1
2	583.30.015.044	PLEUEL-REP.SATZ LC4 620/640 CCM L=141,5MM	CONNECTING ROD REPAIR SET LC4 620/640 CCM L=141,5MM	1
4	565.30.081.000	PASSSCHEIBE 36X48X0,10	SHIM WASHER 36X48X0,10	X
4	565.30.081.100	PASSSCHEIBE 36X48X0,15	SHIM WASHER 36X48X0,15	X
4	565.30.081.300	PASSSCHEIBE 36X48X0,30	SHIM WASHER 36X48X0,30	X
5	0888 030050	SCHEIBENFEDER DIN6888-3X5X13	WOODRUFF KEY DIN6888-3X5X13	1
6	6 946 005	SCHEIBENFEDER 5X6,5 GEHÄRTET	WOODRUFF KEY 5X6,5 HARDED	2
7	560.30.081.000	PASSSCHEIBE 30,5X45X0,10	THRUST WASHER 30X42X0,1	X
7	560.30.081.100	PASSSCHEIBE 30,5X45X0,15	THRUST WASHER 30X42X0,15	X
7	560.30.081.200	PASSSCHEIBE 30,5X45X0,30	THRUST WASHER 30X42X0,3	X
8	580.30.082.000	ZYLINDERROLLENLAGER NJ 306 C3	CYL.ROLLER BEARING NJ 306 C3	1
9	565.30.123.000	ZYLINDERROLLENLAG.NJ 207 SKF	CYLINDER ROLLER BEARING NJ 207	1
10	0760 304771	WELLENDICHTRING 30X47X7 VITON	SHAFT SEAL RING 30X47X7 VITON	1
15	583.30.095.000	STAHLSCHEIBE 16 X 30 X 3	STEEL WASHER 16 X 30 X 3	1
16	584.30.028.000	SK-MUTTER M16X1,25 LINKS	HEX NUT M16X1,25 L/S	1
21	580.30.019.000	SPERRKANTRING VSK 20	LOCKING RING VSK 20	1
22	0936 200155	SK.MUTTER DIN0936-M20X1,5	HEXAGON NUT DIN0936-M20X1,5	1
23	0760 122270	WELLENDICHTRING 12 X 22 X 7 B	SHAFT SEAL RING 12 X 22 X 7 B	1
31	575.30.031.000	ÖLABSTREIFRING 89MM	OIL SCRAPER RING 89MM	1
32	575.30.132.000	MINUTENRING 89MM	TAPERED COMPR.PISTON RING 89MM	1
33	575.30.032.000	RECHTECKRING 89MM	RECTANGULAR RING 89MM	1
36	577.30.007.000/ I	KOLBEN I 89MM KPL. GEGOSSEN'99	PISTON I 89MM CPL. CAST '99	1
36	577.30.007.000/ II	KOLBEN II 89MM KPL.GEGOSSEN'99	PISTON II 89MM CPL. CAST '99	1
37	577.30.033.000	KOLBENBOLZEN 22X13X54,2 '99	PISTON BOLT 22X13X54,2 '99	1
41	583.30.031.300	ÖLABSTREIFRING 101X2,5	OIL SCRAPER RING 101X2,5	1
42	583.30.932.100	MINUTENRING 101X1,25	TAP.COMPR.PISTON RING 101X1,25	1
44	583.30.833.000	KOLBENBOLZEN 22 X 13 X 60	PISTON PIN 22 X 13 X 60	1
45	580.30.074.100	DRAHTSPRENGRING C 22 X 1,5	CIRCLIP C 22 X 1,5	2
46	584.30.007.000/ I	KOLBEN I KPL.101MM GESCHM.2000	PISTON I CPL.101MM FORGED 2000	1
46	584.30.007.000/ II	KOLBEN II 101MM GESCHM. 2000	PISTON II 101MM FORGED 2000	1
47	584.30.074.000	DRAHTSPRENGRING 22 X 1,6	CIRCLIP 22 X 1,6	2
48	584.30.032.000	L-RING 101X93,5X1,5 2000	L-RING 101X93,5X1,5 2000	1

FIG	TEILNR/PARTNR	BEZEICHNUNG	DESCRIPTION	QTY
1	583.30.055.144	AUSGLEICHSWELLE KPL. LC4'95	BALANCER SHAFT CPL. LC4'95	1
4	0625 160040	RILLENKUGELLAGER TM 16004 C3	GROOVED BALL BEARING 16004 C3	1
5	0625 160030	RILLENKUGELLAGER 16003 C3	GROOVED BALL BEARING 16003 C3	1

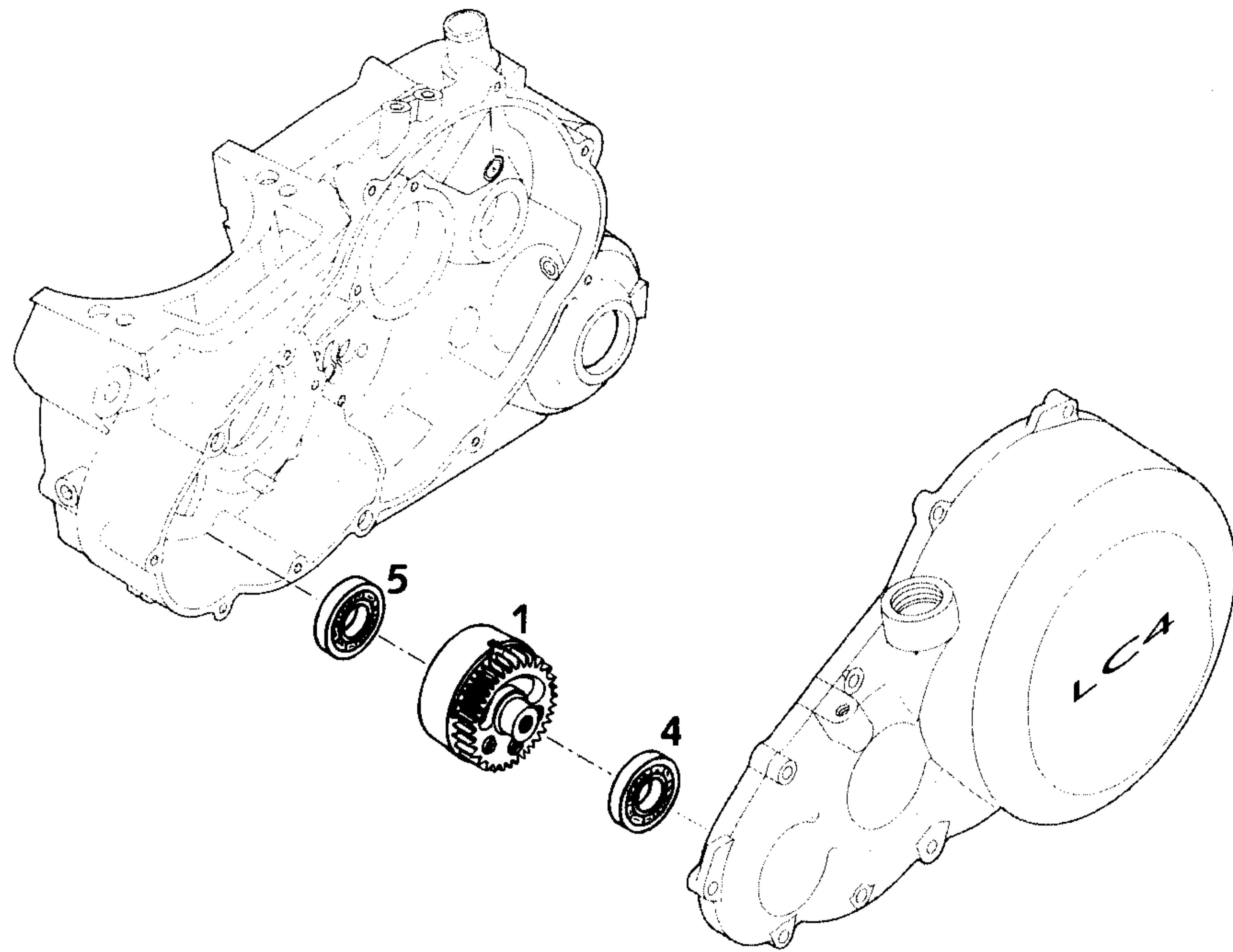
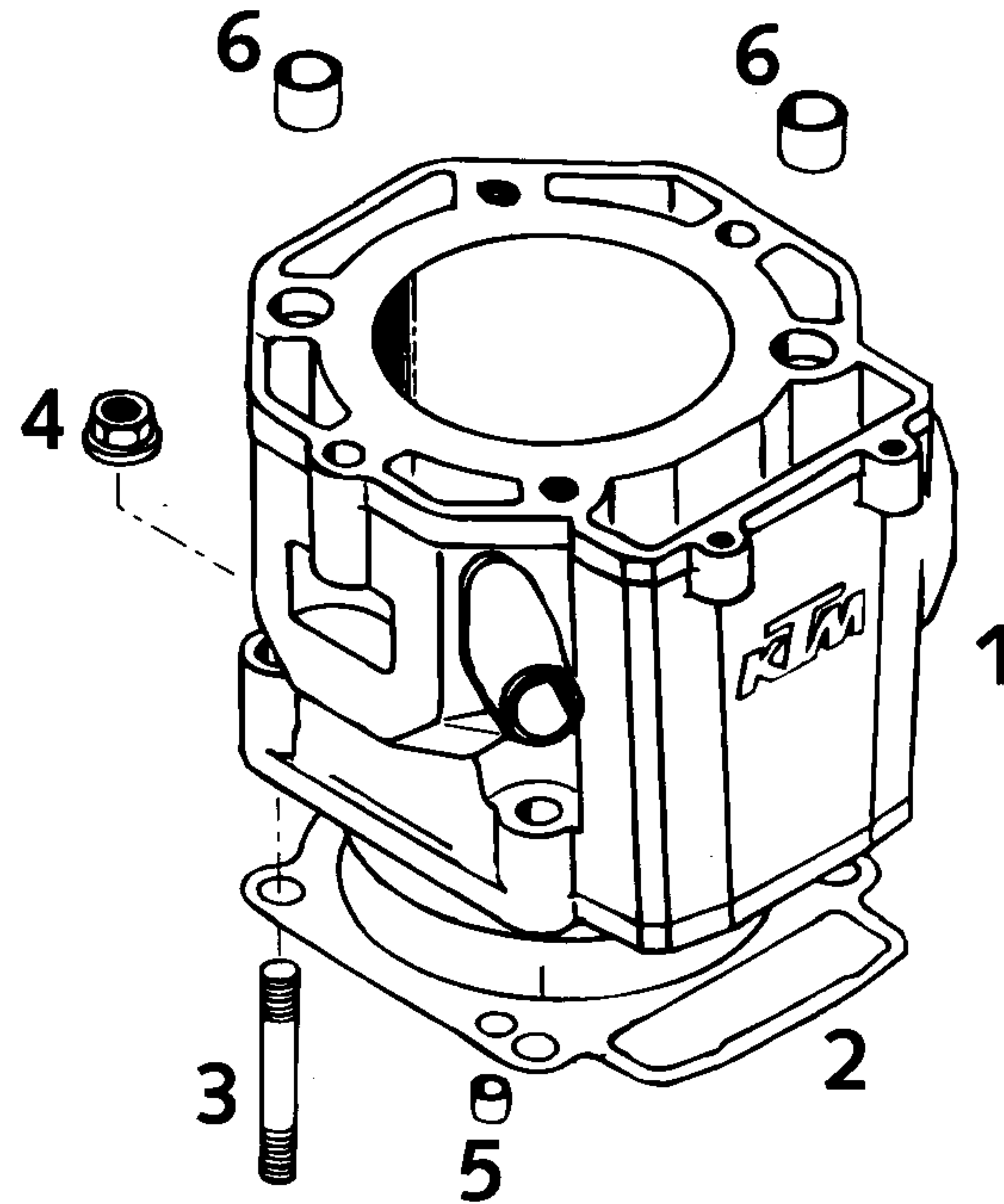

FIG	TEILNR/PARTNR	BEZEICHNUNG	DESCRIPTION	QTY
1	576.30.005.100	ZYLINDER 89MM SCHWARZ 400'97	CYLINDER 89MM BLACK 400'97	1
1	583.30.005.100	ZYLINDER 101MM SCHWARZ 620/640	CYLINDER 101MM BLACK 620/640	1
2	580.30.030.000	ZYL.FUSSDICHTUNG 0,5MM GRÜN 400	CYL. BASE GASKET 0,5MM GREEN 400	1
2	580.30.030.100	ZYL.FUSSDICHTUNG 0,7MM SCHWARZ 640	CYL. BASE GASKET 0,7MM BLACK 640	1
3	0835 100456	STIFTSCHRAUBE DIN0835-M10X45 VERZINKT	STUD DIN0835-M10X45 ZINC COATED	4
4	0331 100003	BUNDMUTTER DIN6923-M10 SW=15	COLLAR NUT DIN6923-M10 WS=15	4
5	490.30.090.000	PASSHÜLSE 9,8 X 7 X 10	DOWEL 9,8 X 7 X 10	2
6	583.30.023.000	PASSHÜLSE 17 X 14 X 9,5	DOWEL 17,0 X 14 X 9,5	2



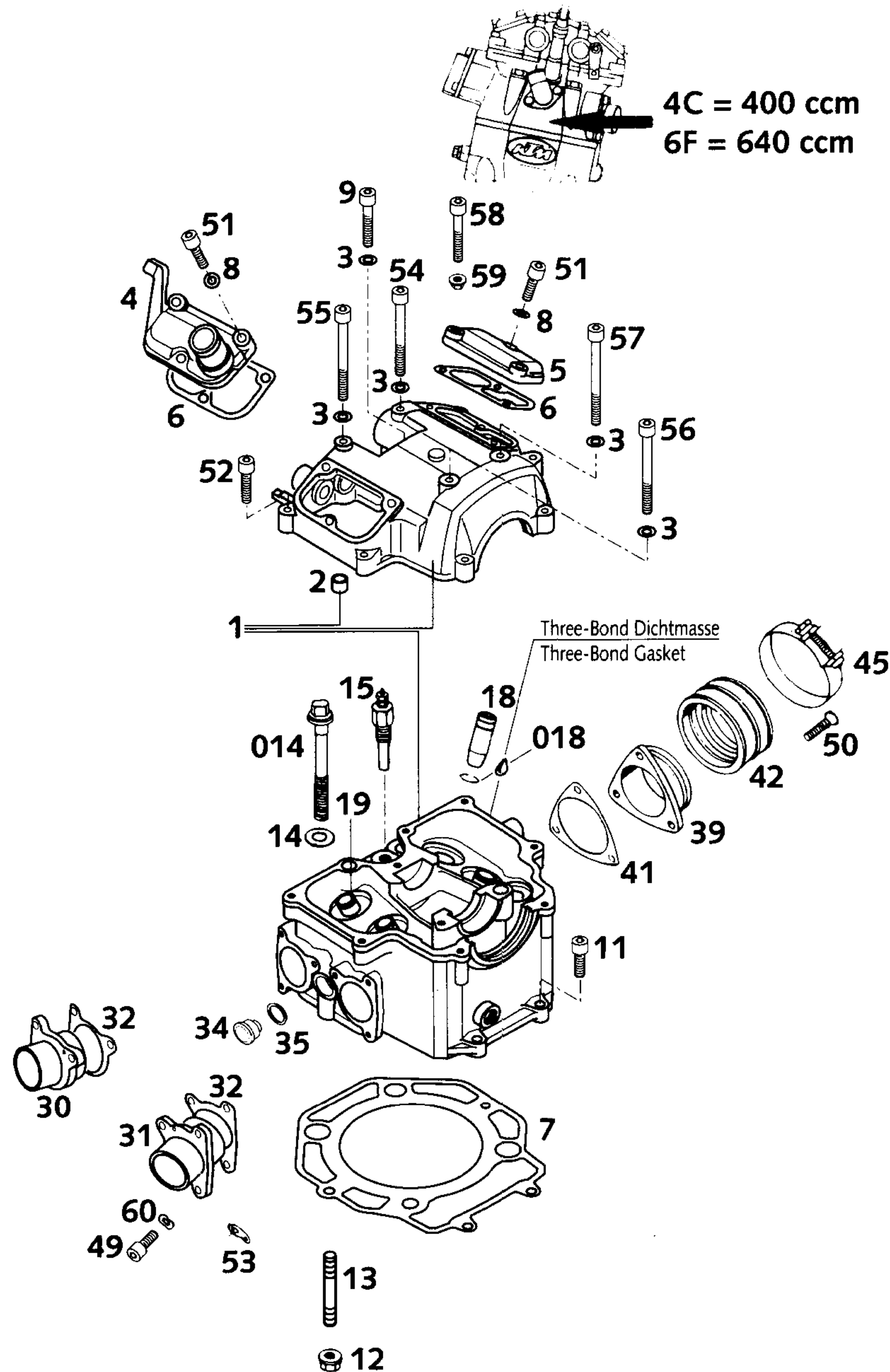

FIG	TEILNR/PARTNR	BEZEICHNUNG	DESCRIPTION	QTY
1	576.36.020.300	ZYLINDERKOPF KPL. 400 LC4 '97	CYLINDER HEAD CPL. 400 LC4 '97	1
1	584.36.020.000	ZYLINDERKOPF KPL. 640 LC4 '98	CYLINDER HEAD CPL. 640 LC4 '98	1
2	490.30.090.000	PASSHÜLSE 9,8 X 7 X 10	DOWEL 9,8 X 7 X 10	1
3	580.36.065.100	CU-DICHTRING 6 X 10 X 2	CU-SEAL RING 6 X 10 X 2	5
4*	580.36.152.600	VENTILDECKEL VORNE '99	VALVE COVER FRONT '99	1
5	580.36.052.000	VENTILDECKEL HINTEN	VALVE COVER REAR	1
6	580.36.053.000	VENTILDECKELDICHUNG	VALVE COVER GASKET	2
7	575.30.036.000	ZYLINDERKOPFDICHTUNG 90,3 MM 400 LC4	CYLINDER HEAD GASKET 90,3 MM 400 LC4	1
7	583.30.036.000	ZYLINDERKOPFDICHTUNG 101,3 MM 612/620/640 LC4	CYLINDER HEAD GASKET 101,3 MM 612/620/640 LC4	1
8	0603 061001	CU-DICHTRING DIN7603- 6X10X1	CU-SEAL RING DIN7603- 6X10X1	6
9	0912 060353	ISK.SCHRAUBE DIN0912-M 6X35	AH SCREW DIN0912-M 6X35	1
11	0912 060253	ISK.SCHRAUBE DIN0912-M 6X25	AH SCREW DIN0912-M 6X25	2
12	490.30.028.000	BUNDMUTTER M8 - 8MM HOCH	COLLAR NUT M8 - 8MM HIGH	2
13	0835 080355	STIFTSCHR. DIN0835-M 8X35 10.9 400 LC4	STUD DIN0835-M 8X35 10.9 400 LC4	2
13	543.30.043.000	STIFTSCHRAUBE DIN0835-M 8X40 600/612/620/640 LC4	STUD DIN0835-M 8X40 600/612/620/640 LC4	2
14	580.36.098.000	CU-DICHTRING 10 X 20 X 1	CU-SEAL RING 10 X 20 X 1	4
014	580.36.099.100	BUNDSCHRAUBE M10X80 SK13MM	COLLAR SCREW M10X80 SK13MM	4
15	420.11.252.000	TEMPERATURSCHALTER VDO	TEMPERATURE SWITCH VDO	1
018	0993 012000	SPRENGRING DIN7993-RW12	CIRCLIP DIN7993A-RW12	4
18	580.36.026.600	VENTILFÜHRUNG EINLASS	VALVE GUIDE INTAKE	2
19	580.36.126.600	VENTILFÜHRUNG AUSLASS	VALVE GUIDE EXHAUST	2
30	580.36.040.000	AUSPUFFFLANSCH RECHTS	EXHAUST FLANGE R/S	1
31	580.36.140.000	AUSPUFFFLANSCH LINKS	EXHAUST FLANGE L/S	1
32	580.36.041.000	AUSPUFFFLANSCHDICHTUNG	EXHAUST FLANGE GASKET	2
34	583.36.024.000	VERSCHLUSSPFROPFEN	PLUG SLS BORE	1
35	584.36.054.000	CU-FÜLLRING 12 X 16 X 2	CU-SEAL RING 12 X 16 X 2	1
39	581.36.042.040	ANSAUGSTUTZEN D=40MM	INTAKE FLANGE D=40MM	1
41	581.36.043.000	ANSAUGSTUTZENDICHTUNG	INTAKE FLANGE GASKET	1
42	581.36.044.100	GUMMIMUFFE D=38MM 400-660 LC4	INTAKE BOOT D=38MM 400-660 LC4	1
42	584.36.044.000	GUMMIMUFFE FÜR MIKUNI VERGASER 640 LC4-E	INTAKE BOOT FOR MIKUNI CARBU. 640 LC4-E	1

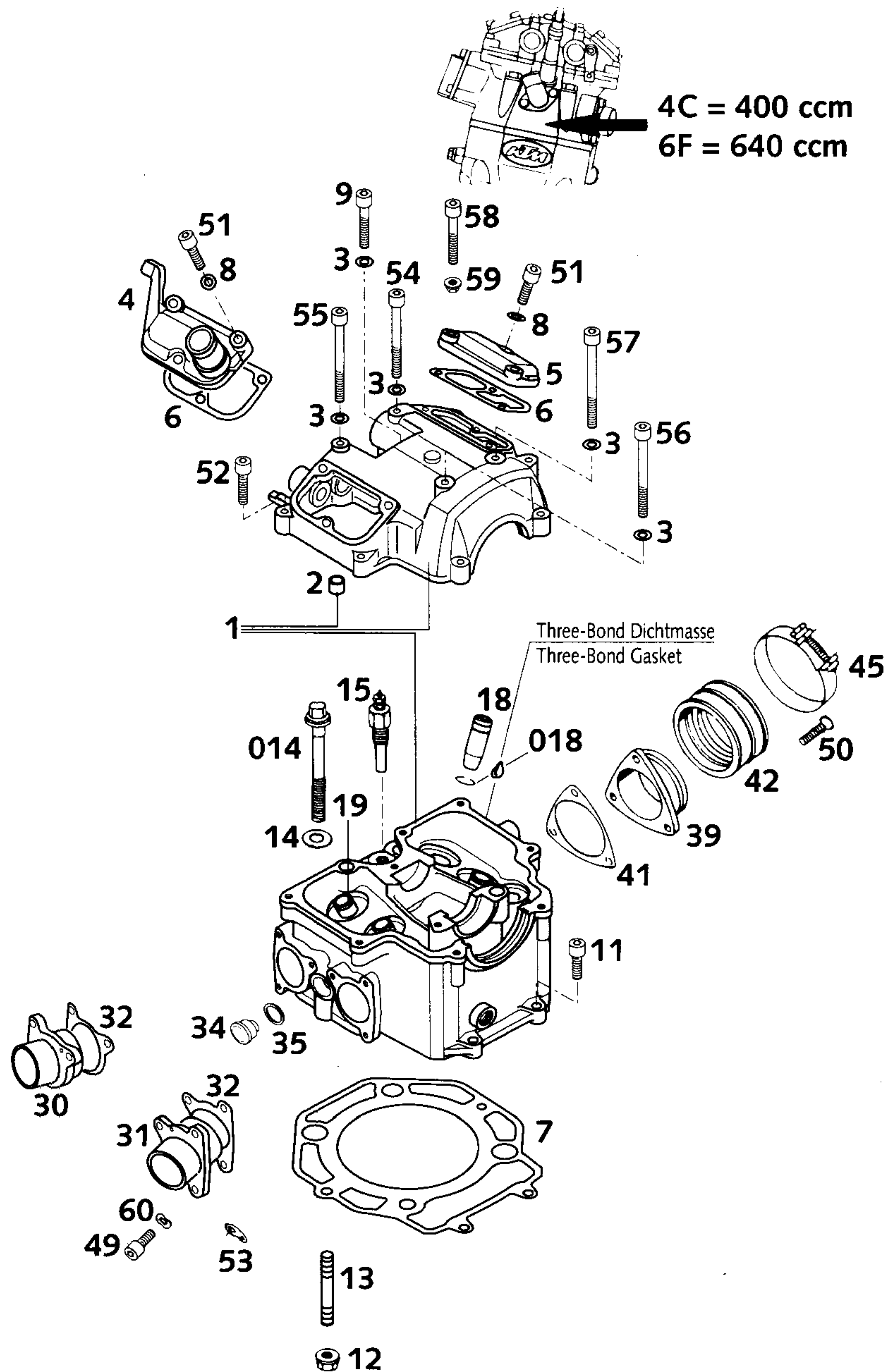

FIG	TEILNR/PARTNR	BEZEICHNUNG	DESCRIPTION	QTY
45	565.30.061.000	SCHELLE SM12/A60	CLAMP SM12/A60	2
49	0912 060163	ISK.SCHRAUBE DIN0912-M 6X16	AH SCREW DIN0912-M 6X16	6
50	0991 060203	SENKSCHRAUBE DIN7991-M 6X20	FLAT HEAD SCREW DIN7991-M 6X20	3
51	0912 060203	ISK.SCHRAUBE DIN0912-M 6X20	AH SCREW DIN0912-M 6X20	6
52	0912 060253	ISK.SCHRAUBE DIN0912-M 6X25	AH SCREW DIN0912-M 6X25	5(6)
53	510.05.074.000	FEDERLASCHE	RETAINING PLATE	X
54	0912 060501	ISK.SCHRAUBE DIN0912-M 6X50	AH SCREW DIN0912-M 6X50	1
55	0912 060551	ISK.SCHRAUBE DIN0912-M 6X55	AH SCREW DIN0912-M 6X55	1
56	0912 060653	ISK.SCHRAUBE DIN0912-M 6X65	AH SCREW DIN0912-M 6X65	1
57	0912 060703	ISK.SCHRAUBE DIN0912-M 6X70	AH SCREW DIN0912-M 6X70	1
58	0912 060404	ISK.SCHRAUBE DIN0912-M 6X40	AH SCREW DIN0912-M 6X40	1(X)
59	565.09.064.100	STOVER-FLANSCHMUTTER M6 10.9	SELF LOCKING NUT M6 10.9	X
60	0137 060000	FEDERSCHEIBE DIN0137-B 6	SPRING WASHER DIN0137-B 6	6

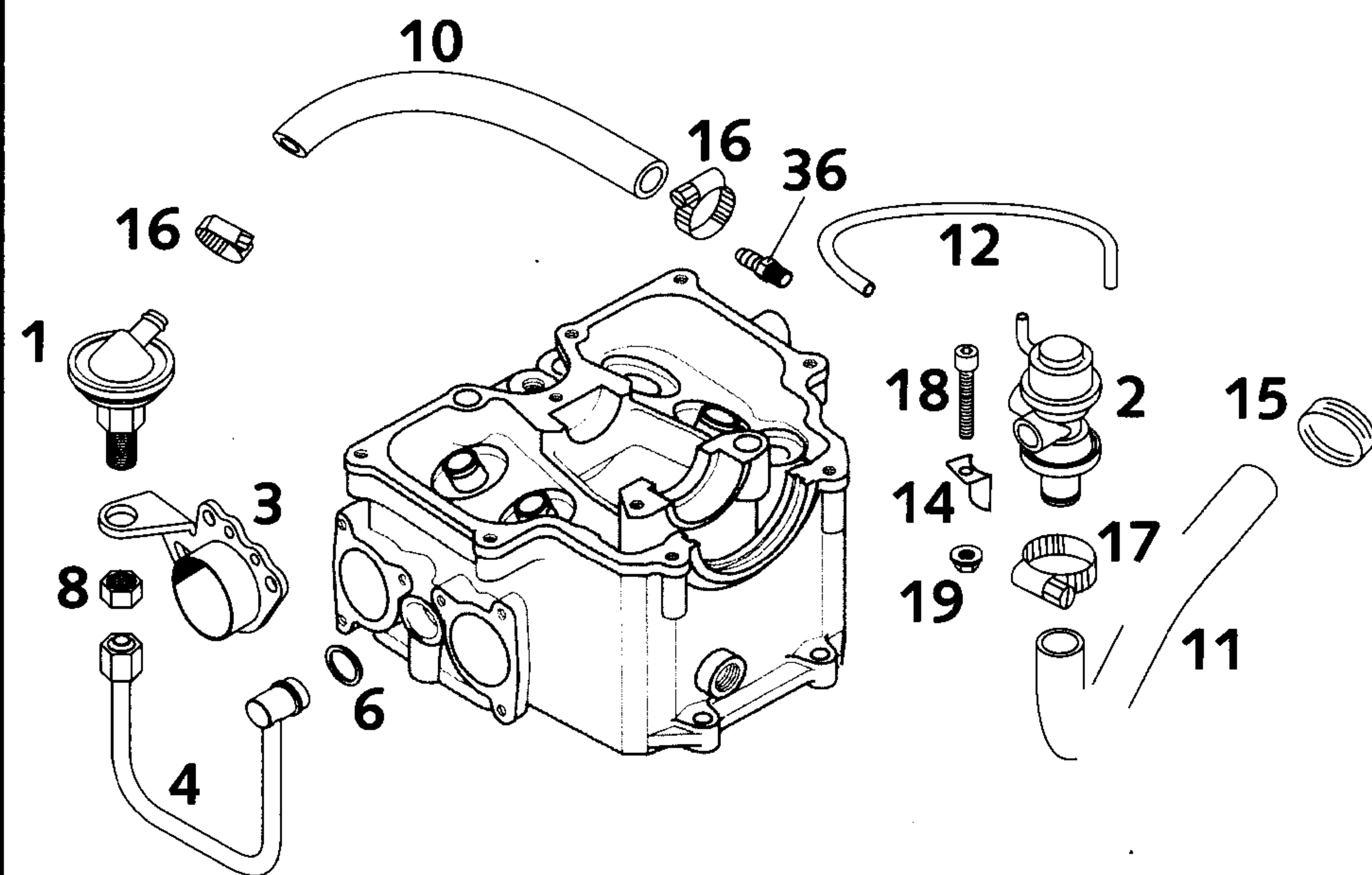

FIG	TEILNR/PARTNR	BEZEICHNUNG	DESCRIPTION	QTY
1	584.05.026.000	SEKUNDÄR LUFT-VENTIL '97	SEKONDARY AIRVALVE '97	1
2	584.05.024.000	STEUERVENTIL ASV '97	CONTROL VALVE ASV '97	1
3	584.36.039.000	AUSPUFFFLANSCH KPL. FÜR SLS	EXHAUST FLANGE CPL. FOR SLS	1
4	584.05.027.000	SLS-VERBINDUNGSROHR '97	CONNECTING TUBE SLS '97	1
6	584.36.054.000	CU-FÜLLRING 12 X 16 X 2	CU-SEAL RING 12 X 16 X 2	1
8	584.05.023.000	SK.MUTTER M16X1,5	HEXAGON NUT M16X1,5	1
10	583.35.025.001	KÜHLERGEWEBESCHLAUCH 12 X 3	RADIATOR HOSE(REENFORCED)12X3	0,27
11	584.05.028.000	FORMSCHLAUCH 18X3,5	PREFORMED HOSE 18X3,5	1
12	584.05.029.001	ND-SCHLAUCH 4X9 PER METER	ND-HOSE 4X9 PER METER	0,27
14	584.05.025.000	HALBLECH FÜR STEUERVENTIL	BRACKET FOR CONTROL VALVE	1
15	000.50.250.906	WV-SPANNSCHELLE D=25MM OETIKER	WV-CLAMP D=25MM OETIKER	1
16	583.35.099.000	SCHLAUCHBINDER GEMI 10-16	HOSE CLAMP GEMI 10-16	2
17	100.01.020.000	SCHLAUCHKLEMMME GEMI 16/27	HOSE CLAMP GEMI 16/27	1
18	0912 060404	ISK.SCHRAUBE DIN0912-M 6X40	AH SCREW DIN0912-M 6X40	1
19	565.09.064.100	STOVER-FLANSCHMUTTER M6 10.9	SELF LOCKING NUT M6 10.9	1
36	583.36.020.090	UNTERDRUCKANSCHLUSS M6X1	VACUUM CONNECTION M6X1	1

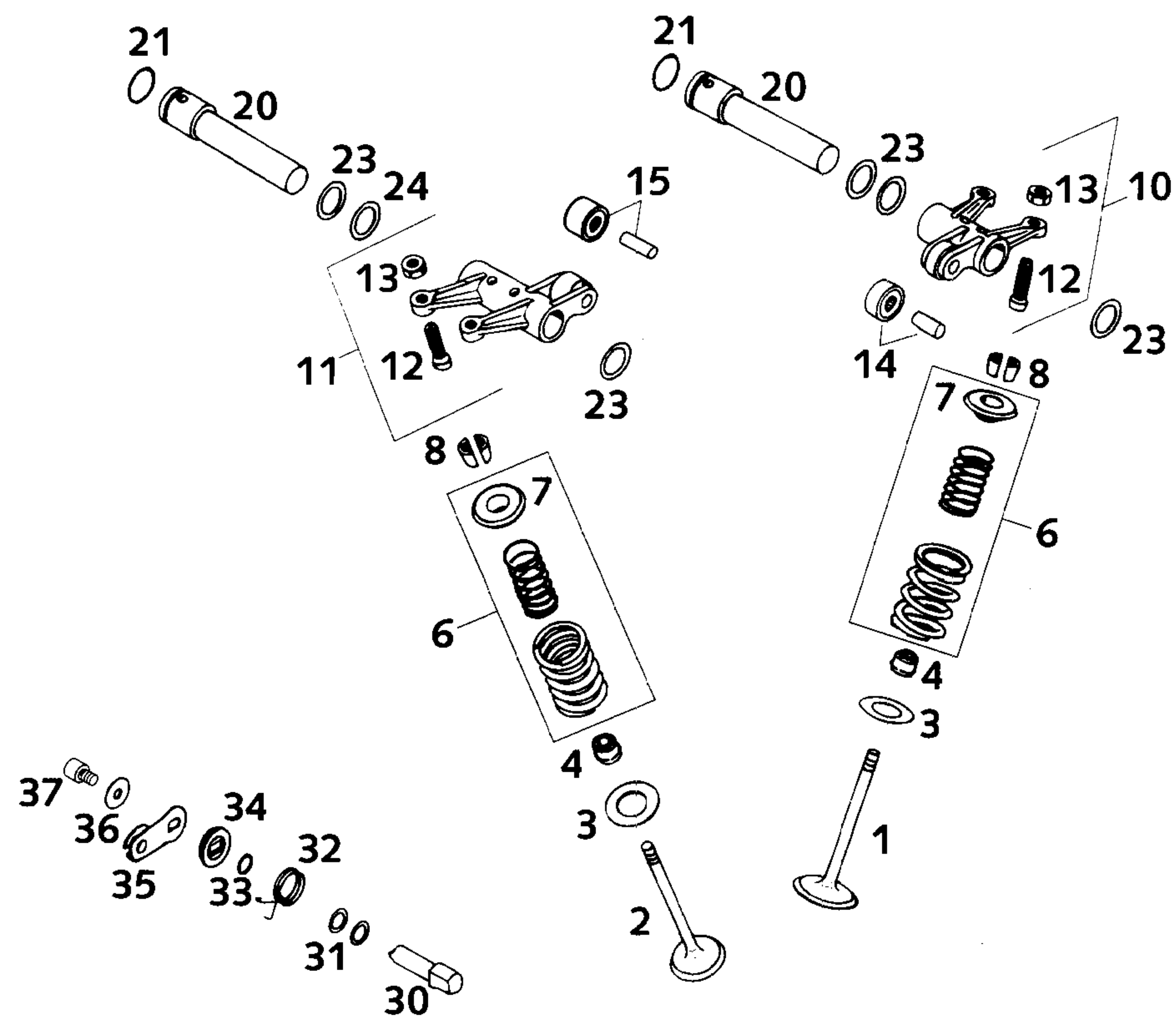

FIG	TEILNR/PARTNR	BEZEICHNUNG	DESCRIPTION	QTY
1	580.36.030.000	EINLASSVENTIL 36 MM	INTAKE VALVE 36 MM	2
2	580.36.031.000	AUSLASSVENTIL 30 MM	EXHAUST VALVE 30 MM	2
3	580.36.027.000	ANLAUFSCHLEIBE 12,2X29,5X1	STOP DISK 12,2X29,5X1	4
4	580.36.028.000	VENTILSCHAFTDICHTUNG	VALVE-SHAFT SEALING	4
6	583.36.029.044	VENTILFEDERSATZ PROGRESSIV '95	PROGR.VALVE SPRING KIT'95	4
7	580.36.032.700	VENTILFEDERTELLER ALU '95	VALVE-SPRING RETAINER '95	4
8	580.36.033.000	VENTILKEGELSTÜCK MK7	VALVE COLLET MK7	8
10	580.36.060.644	KIPPHEBEL EINLASS KPL.	ROCKER ARM INTAKE CPL.	1
11	583.36.061.044	KIPPHEBEL AUSLASS KPL.	ROCKER ARM EXHAUST CPL.	1
12	580.36.062.600	EINSTELLSCHRAUBE KPL. M 7X0,75	ADJUSTMENT SCREW CPL. M 7X0,75	4
13	0934 070756	SK.MUTTER DIN0934-M 7X0,75	HEXAGON NUT DIN0934-M 7X0,75	4
14	580.36.061.090	KIPPHEBELROLLE KPL. EINLASS	ROCKER ARM ROLLER CPL. INTAKE	1
15	583.36.061.090	KIPPHEBELROLLE KPL. AUSLASS	ROCKER ARM ROLLER CPL. EXHAUST	1
20	580.36.056.100	KIPPHEBELWELLE L=96MM	ROCKER ARM SHAFT L=96MM	2
21	580.36.095.000	O-RING 15,08X2,62 NBR 70	O-RING 15,08 X 2,62 NBR 70	2
23	0988 162210	PASSSCHEIBE DIN0988-16X22X1	THRUST WASHER DIN0988-16X22X1	X
24	0988 162205	PASSSCHEIBE DIN0988-16X22X0,5	THRUST WASH. DIN0988-16X22X0,5	X
30	580.36.050.100	DEKO-WELLE	DECOMPRESSION SHAFT	1
31	543.34.015.000	SCHEIBE 10X14X0,5 STAHL	WASHER 10X14X0,5 STEEL	X
31	543.34.015.100	SCHEIBE 10X14X0,3 STAHL	WASHER 10X14X0,3 STEEL	X
31	543.34.015.200	SCHEIBE 10X14X0,15 STAHL	WASHER 10X14X0,15 STEEL	X
32	580.36.059.200	DEKO-HEBELFEDER	DECOMP.LEVER SPRING 1,8MM	1
33	0770 100221	O-RING 10,00X2,20 SILICON	O-RING 10,00X2,20 SILICON	1
34	580.36.048.000	ABDECKSCHEIBE	COVER DISK	1
35	580.36.049.500	DEKO-WELLENHEBEL	DECOMPRESSION LEVER	1
36	0021 060003	SCHEIBE DIN9021-A 6,4	WASHER DIN9021-A 6,4	1
37	0912 060103	ISK.SCHRAUBE DIN0912-M 6X10	AH SCREW DIN0912-M 6X10	1

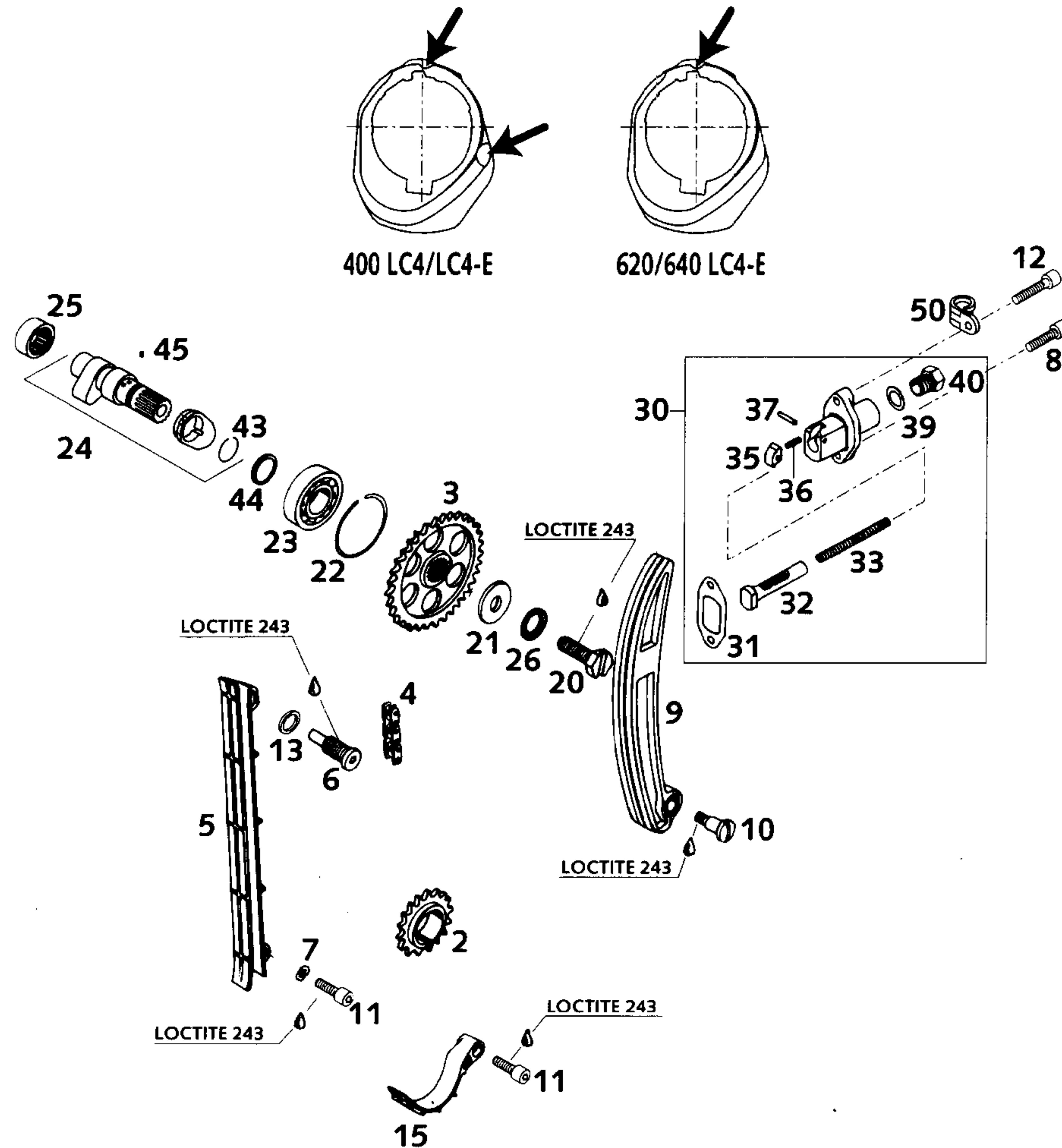
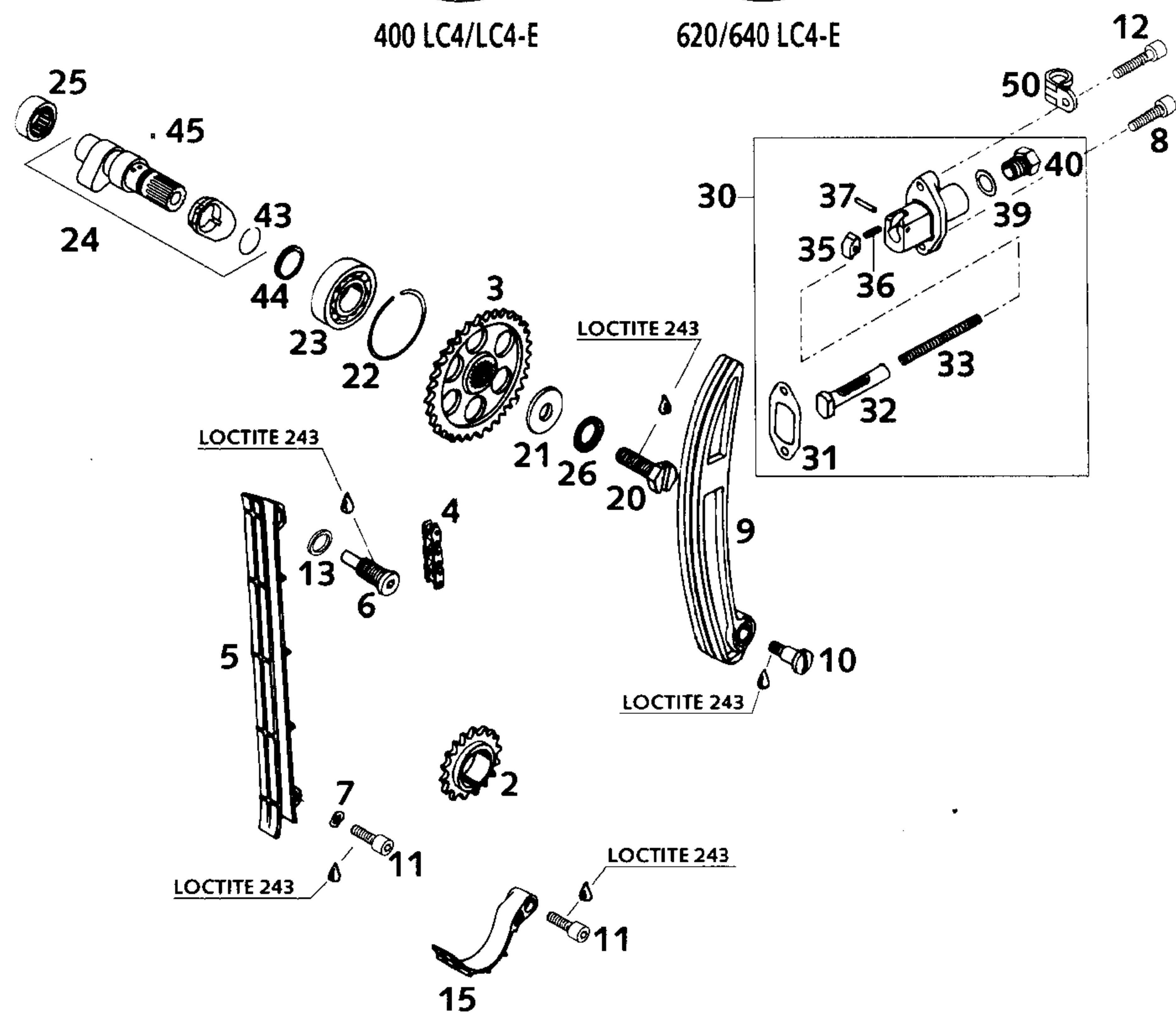
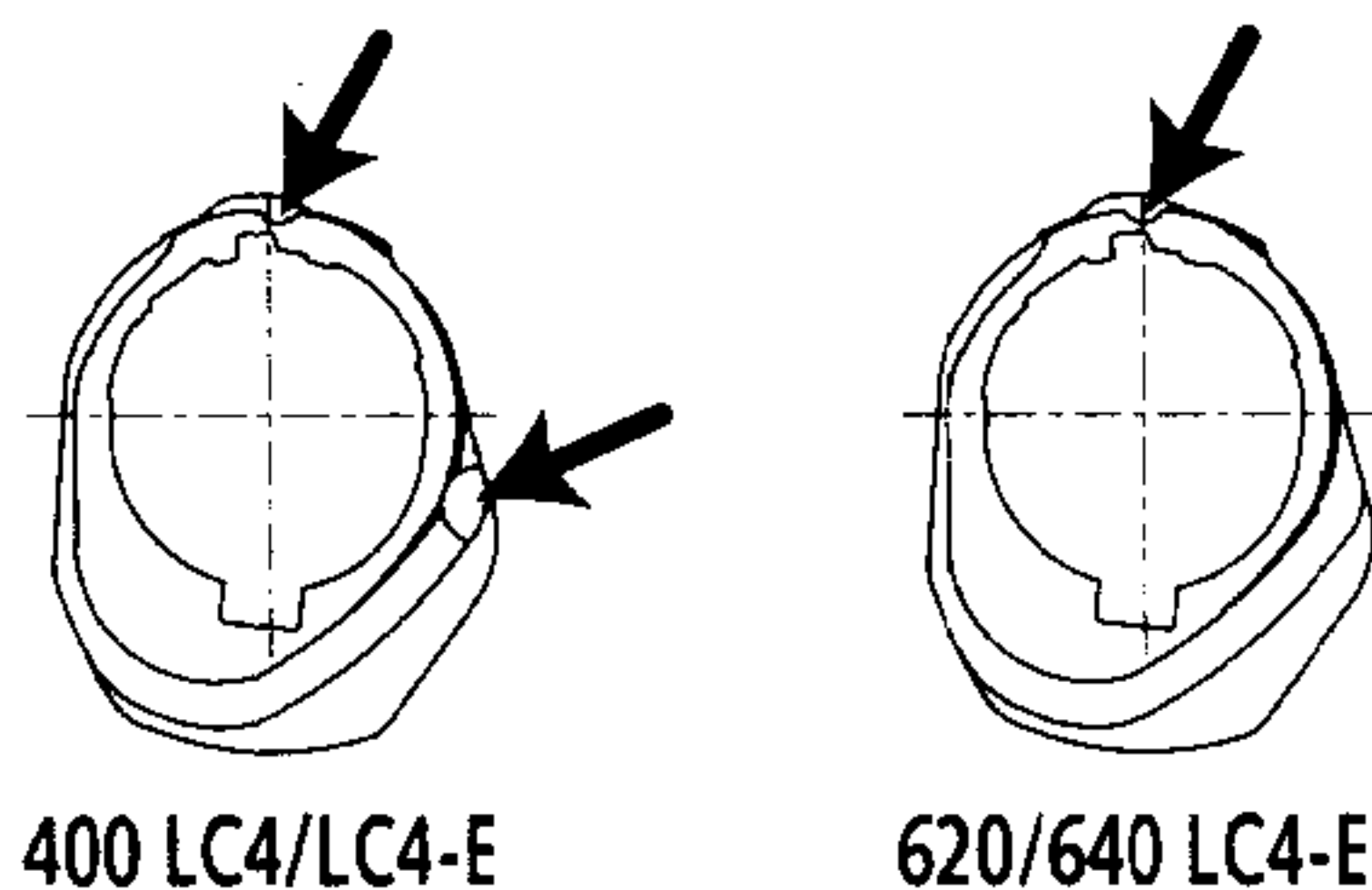

FIG	TEILNR/PARTNR	BEZEICHNUNG	DESCRIPTION	QTY
2	580.36.014.000	STEUERRITZEL 17-Z	TIMING GEAR 17-T	1
3	576.36.011.000	NOCKENWELLENRAD „02“ 400 LC4	CAMSHAFT GEAR 34-T „02“ '97 400 LC4	1
3	583.36.011.001	NOCKENWELLENRAD 34-Z „01“ '94 540/620/640 LC4	CAMSHAFT GEAR 34-T „01“ '94 540/620/640 LC4	1
4	576.36.013.000	STEUERKETTE C107C / 98 ROLLEN 400 LC4	TIMING CHAIN C107C / 98 LINKS 400 LC4	1
4	580.36.013.000	STEUERKETTE C107C / 100 ROLLEN 500/540/600/612/620/640 LC4	TIMING CHAIN C107C / 100 LINKS 500/540/600/612/620/640 LC4	1
5	575.36.001.000	STEUERKETTENFÜHRUNG 350/400 LC4	TIMING CHAIN GUIDE 350/400 LC4	1
5	580.36.001.000	STEUERKETTENFÜHRUNG 540/600/612/620/640 LC4	TIMING CHAIN GUIDE 540/600/612/620/640 LC4	1
6	580.36.009.000	KETTENFÜHRUNGSSCHRAUBE	CHAIN GUIDE SCREW	1
7	0137 060000	FEDERSCHEIBE DIN0137-B 6	SPRING WASHER DIN0137-B 6	1
8	0912 060253	ISK.SCHRAUBE DIN0912-M 6X25	AH SCREW DIN0912-M 6X25	1
9	575.36.002.000	STEUERKETTENSANNER 350/400 LC4	TIMING CHAIN TENSIONER 350/400 LC4	1
9	580.36.002.000	STEUERKETTENSANNER 540/600/612/620/640 LC4	TIMING CHAIN TENSIONER 540/600/612/620/640 LC4	1
10	0923 080120	FLACHKOPFSCHRAUBE M 8X12	FLAT HEAD SCR. M 8X12	1
11	0912 060208	ISK.SCHRAUBE DIN0912-M 6X20 SS	AH SCREW DIN0912-M 6X20 SS	2
12	0912 060303	ISK.SCHRAUBE DIN0912-M 6X30	AH SCREW DIN0912-M 6X30	1
13	580.38.022.100	CU-DICHTRING 12 X 16 X 2	CU-SEAL RING 12 X 16 X 2	1
15	583.36.018.000	AUSFALLSICHERUNG	SECURING GUIDE LC4'94	1
20	583.36.112.000	MITNEHMERSCHRAUBE M10X25	DRIVING SCREW M10X25	1
21	580.36.012.000	STAHLSCHEIBE 10 X 28 X 3	WASHER 10 X 28 X 3 HARDENED	1
22	580.36.096.000	SPRENGRING SB 42	CIRCLIP SB 42	1
23	0625 060040	RILLENKUGELLAG. TM-6004 C3 LLB	GROOVED BALL BEARING 6004 C3	1
24	576.36.110.044	NOCKENWELLE KPL. 400 LC4/LC4-E	CAMSHAFT CPL. 400 LC4/LC4-E	1
24	583.36.110.044	NOCKENWELLE 620/640 LC4-E	CAMSHAFT CPL. 620/640 LC4-E	1
25	580.36.097.000	NADELLAGER BK 2012	NEEDLE BEARING BK 2012	1
26	360.03.014.200	SCHNORR-SICHERUNGSSCHEIBE 10MM	LOCKING WASHER 10MM	1
30	580.36.003.144	AUTOMATIKSANNER KPL.'88	AUTOM.TENSIONER CPL. '88	1
31	580.36.005.100	SPANNERDICHTUNG 1,5 MM	TENSIONER GASKET 1,5 MM	1

FIG	TEILNR/PARTNR	BEZEICHNUNG	DESCRIPTION	QTY
32	580.36.004.100	DRUCKBOLZEN	PRESSURE BOLT	1
33	580.36.006.100	DRUCKFEDER 0,9MM	PRESSURE SPRING 0,9MM	1
35	580.36.007.100	KLINKE	RATCHETING PAWL	1
36	580.36.007.050	DRUCKFEDER F. KLINKE	PRES.SPRING F.RATCHETING PAWL	1
37	0402 031780	NADELROLLE DIN5402 NRB 3X17,8	NEEDLE ROL.DIN5402 NRO 3X17,8	1
39	580.38.022.000	CU-DICHTRING DIN7603-12X18X1,5	CU-SEAL RING DIN7603-12X18X1,5	1
40	580.36.008.100	VERSCHLUSSSCHRAUBE M12X1,5	PLUG M12X1,5 ALU	1
43	0417 200120	SPRENGRING SW20	CIRCLIP WS20	1
44	583.36.015.000	STUFENRING	STEPPED RING '95	1
45	583.36.016.052	FEDER FÜR AUTODEKO '95	SPRING FOR AUTO-DECOMPR. '95	1
50	542.11.052.000	SHELLE RSGU 24/15	CLAMP RSGU 24/15	1



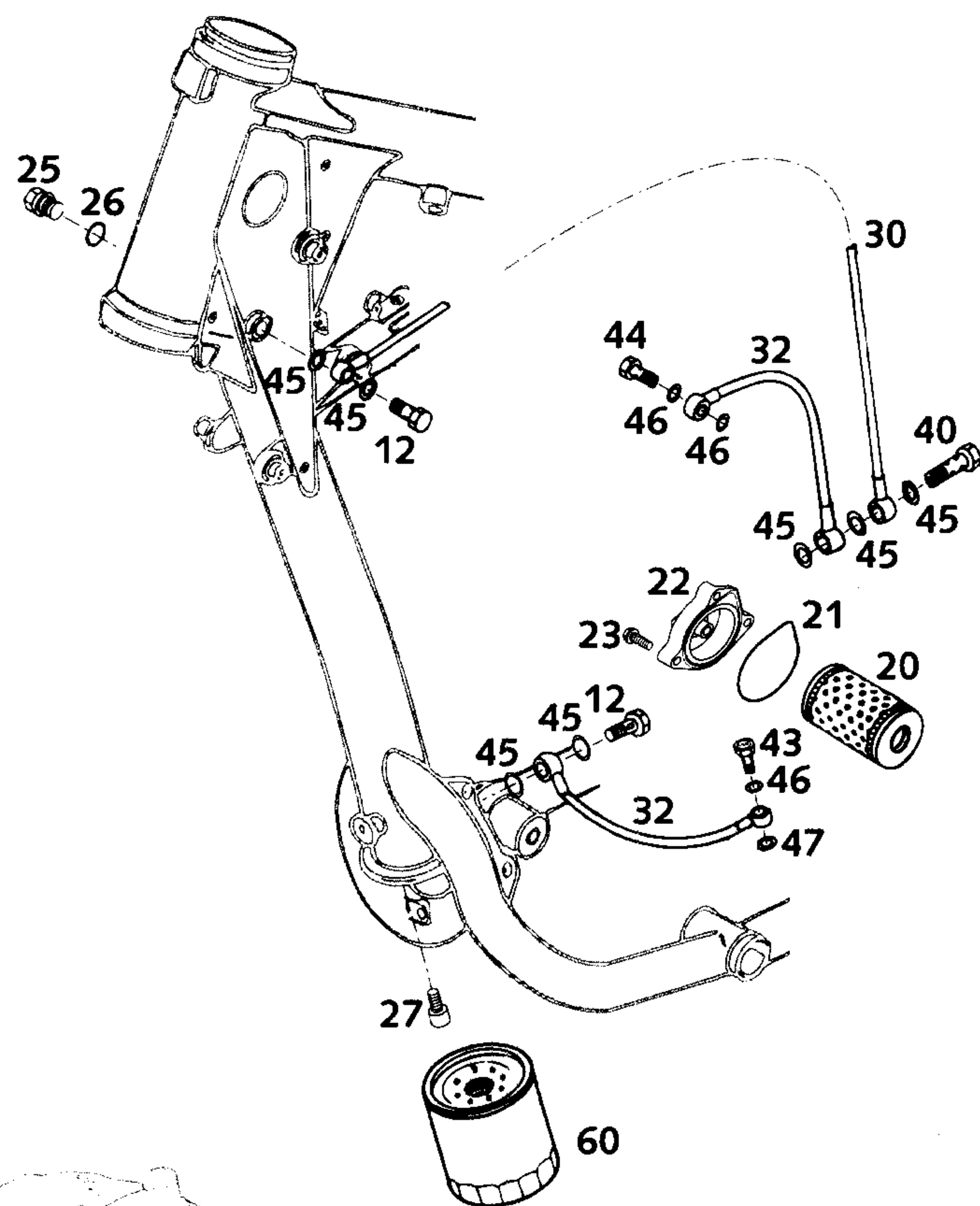

FIG	TEILNR/PARTNR	BEZEICHNUNG	DESCRIPTION	QTY
1	580.38.001.100	ÖLPUMPENRAD 31-Z	OIL PUMP GEAR 31-T	1
2	0402 251980	NADELROL. DIN5402 NRA 2,5X19,8	NEEDLEROL. DIN5402 NRA 2,5X19,8	2
3	0015 060203	SK.BUNDSCHRAUBE M 6X20 SW=8	HH COLLAR SCREW M 6X20 WS=8	5
4	0015 060253	SK.BUNDSCHRAUBE M 6X25 SW=8	HH COLLAR SCREW M 6X25 WS=8	1
5	580.38.007.700	ÖLPUMPE MIKUNI G-73-10	OIL PUMP MIKUNI G-73-10	2
6	580.38.007.755	ANLAUFSCHIEBE 8,1 X 15 X 0,5	STOP DISK 8,1 X 15 X 0,5	4
7	0799 060000	SICH.SCHIEBE DIN6799-RS 6,0	TAB WASHER DIN6799-RS 6,0	2
8	584.38.001.000	ÖLPUMPENRAD 26-Z	OIL PUMP GEAR 26-T	1
9	580.30.021.000	ÖLABLASSCHR. M. MAGNET M12X1,5	OILDRAIN PLUG W. MAGNET M12X1,5	1
12	543.13.025.000	HOHLSCHRAUBE M10 X 1	HOLLOW SCREW M10 X 1	2
13	580.38.028.000	VENTILKOLBEN D=10MM	VALVE PISTON D=10MM	1
15	580.38.019.100	ÖLVERSCHLUSSCHRAUBE M22X1,5	OIL DRAIN PLUG M22X1,5	1
16	580.38.017.100	CU-DICHTRING DIN7603-22X27X2	CU-SEAL RING DIN7603-22X27X2	1
17	0908 120153	VERSCHL.SCHR. DIN0908-M12X1,5	PLUG DIN0908-M12X1,5	1
18	580.38.022.000	CU-DICHTRING DIN7603-12X18X1,5	CU-SEAL RING DIN7603-12X18X1,5	2
19	580.38.023.300	DRUCKFEDER L=25MM D=1MM	PRESSURE SPRING L=25MM D=1MM	1
20	580.38.005.000	ÖLFILTER LANG	OIL FILTER LONG	1
21	580.30.009.000	DICHTRING ÖLFILTERDECKEL VITON	GASKETRING OILF. COVER VITON	1
22	580.30.008.600	FILTERDECKEL M10X1	FILTER COVER M10X1	1
23	0015 060253	SK.BUNDSCHRAUBE M 6X25 SW=8	HH COLLAR SCREW M 6X25 WS=8	3
25	0910 100003	VERSCHL.SCHR. DIN0910-M10X1	PLUG DIN0910-M10X1	1
26	580.38.022.900	CU-FÜLLRING 10 X 14 X 1,5	CU-SEAL RING 10 X 14 X 1,5	1
27*	0984 060163	ISK.SCHRAUBE DIN6912-M 6X16	AH SCREW DIN7984-M 6X16	1
30	580.38.234.700	ÖLLEITUNG FILTER-RAHMENROHR R10/R10 - 865 MM	OIL LINE FILTER-FRAME TUBE R10/R10 - 865 MM	1
32	583.38.034.000	ÖLLEITUNG KUPP.DECKEL-RAHMEN R10/R8 - 203 MM	OIL LINE CLUTCH COVER-FRAME R10/R8 - 203 MM	2
40	580.38.033.100	DOPPELHOHLSCHRAUBE M10 X 1	DUAL BANJO BOLT M10 X 1	1
43	580.38.130.000	DÜSENSCHRAUBE M 8 X 1 „150“	JET SCREW M 8 X 1 „150“	1
44	580.38.030.000	HOHLSCHRAUBE M 8 X 1 DIN7643	BANJO BOLT M8 X 1 DIN7643	1
45	580.38.032.010	CU-DICHTRING DIN7603-10X14X1	CU-SEAL RING DIN7603-10X14X1	7
46	580.38.032.000	CU-DICHTRING DIN7603- 8X12X1	CU-SEAL RING DIN7603- 8X12X1	3
47	580.38.032.300	CU-FÜLLRING 8 X 12 X 1,5	CU-SEAL RING 8 X 12 X 1,5	1
60	583.38.045.000	SCHRAUBFILTER LC4'94	SCREW TYPE FILTER LC4'94	1

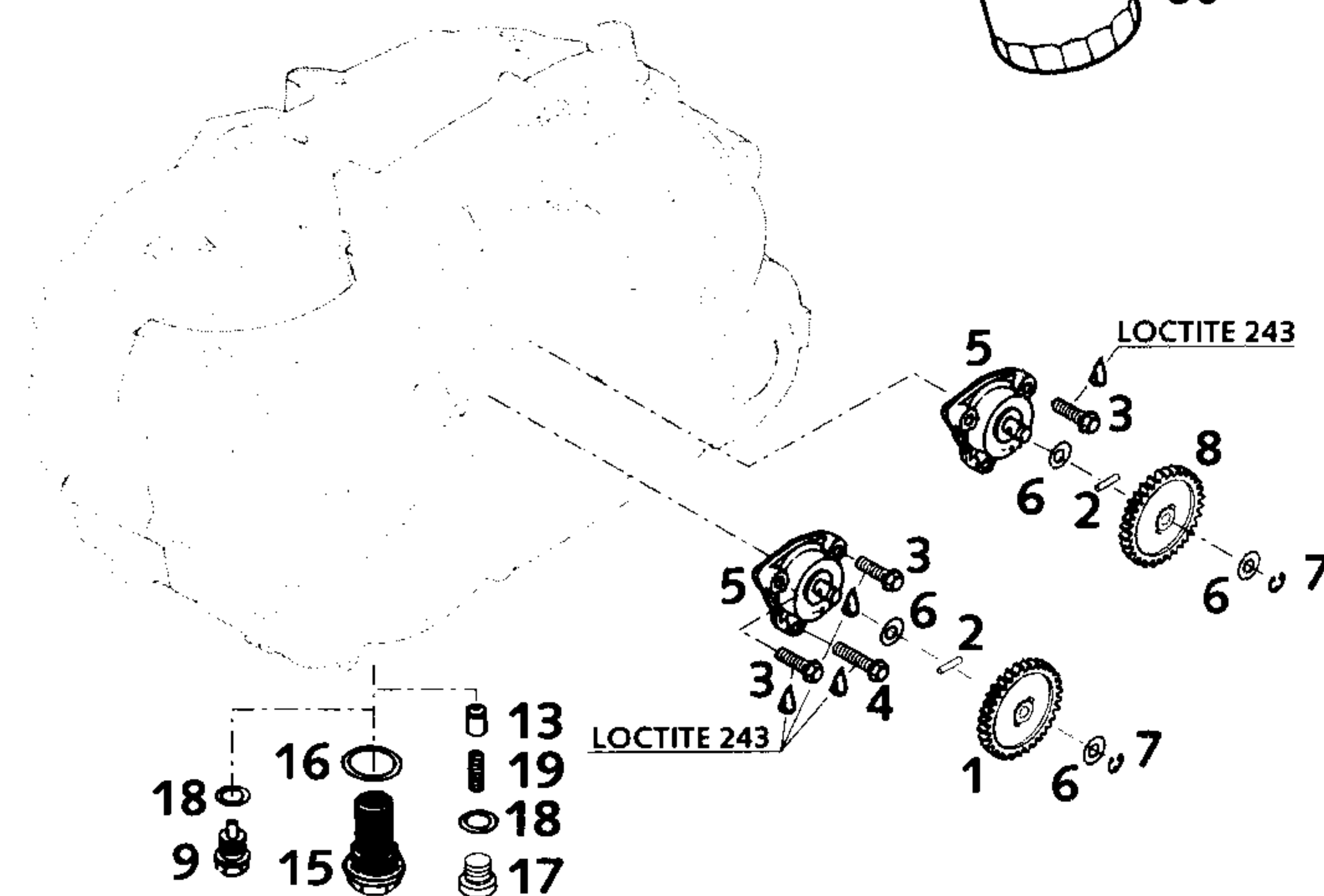
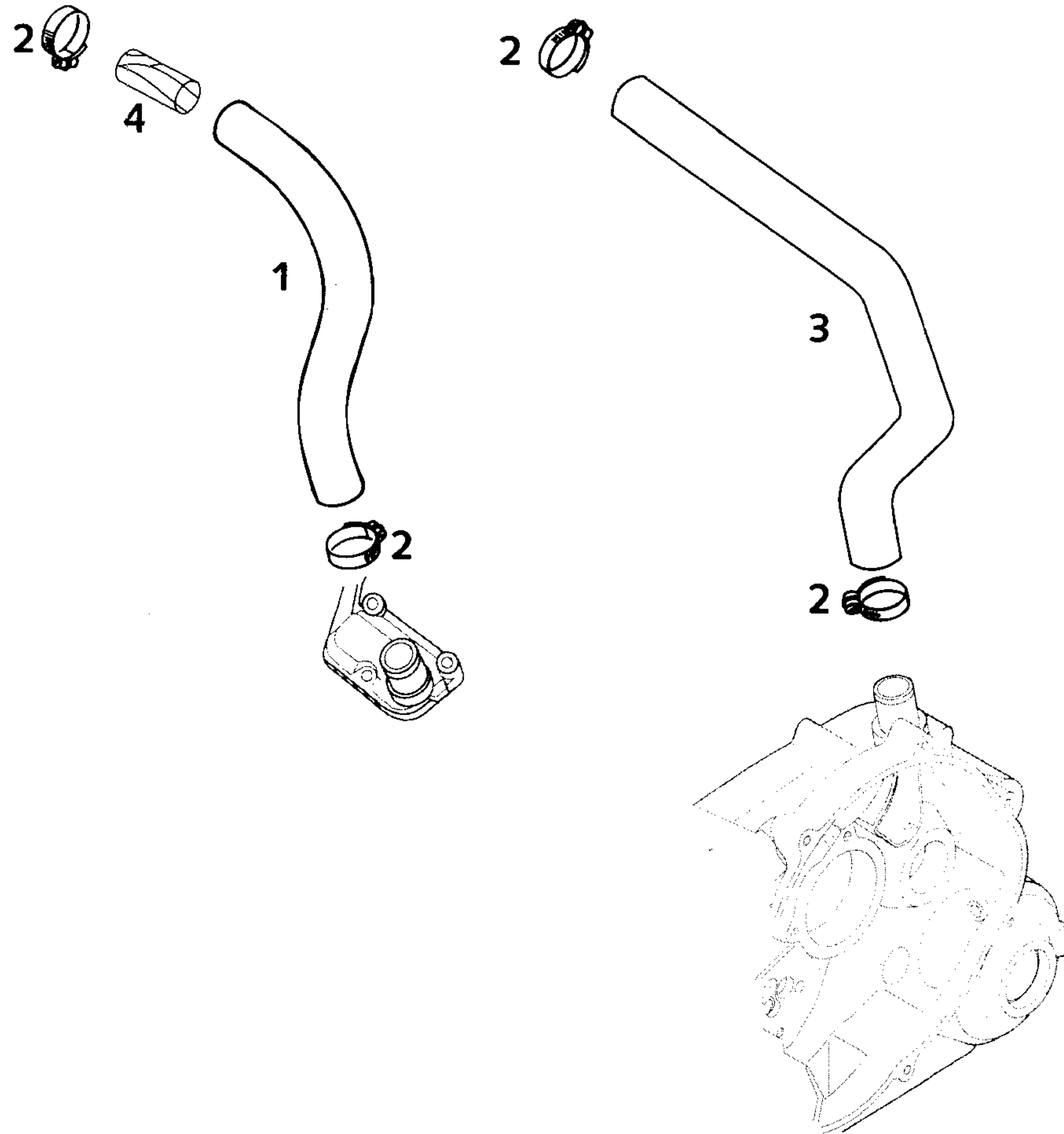

FIG	TEILNR/PARTNR	BEZEICHNUNG	DESCRIPTION	QTY
1	580.35.025.800	ENTLÜFTUNGSSCHLAUCH	BREATHER TUBE TOP	1
2	420.13.037.200	SCHLAUCHBINDER GEMI 12/22	HOSE CLAMP GEMI 12/22	4
3	575.30.090.000	ENTLÜFTUNGSSCHLAUCH '93	BREATHER TUBE ENGINE '93	1
4	584.30.089.000	FILTER FÜR MOTORENTLÜFTUNG '98	FILTER BREATHER SYSTEM '98	1





ACHTUNG !!!
Vor dem Einbau des Vergasers, Bedüsung kontrollieren.
CAUTION !!!
Before mounting the carburetor, check the jetting.

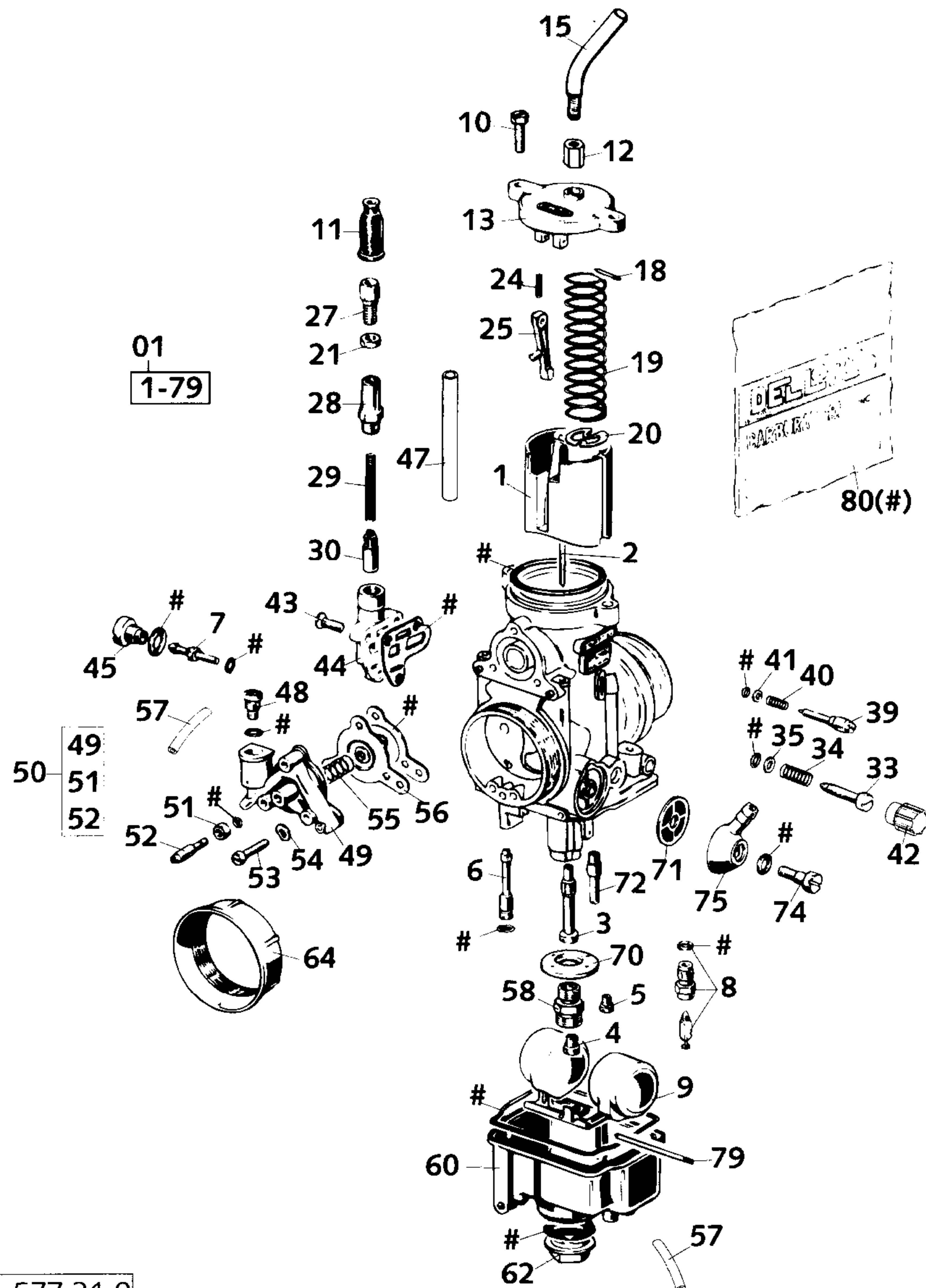

FIG	TEILNR/PARTNR	BEZEICHNUNG	DESCRIPTION	QTY
01	576.31.001.044	VERGASER PHM 38 ND (100197)	CARBURETOR PHM 38 ND (100197)	1
1	572.31.135.000	GASSCHIEBER 50/1 PHM38ND	THROTTLE VALVE 50/1 DM=42MM	1
2	490.31.134.023	DÜSENNADEL K23	JET NEEDLE K23	1
3	577.31.021.264	NADEL DÜSE AR 264	NEEDLE JET AR 264	1
4	570.31.523.130	HAUPTDÜSE 130	MAIN JET 130	1
4	570.31.523.135	HAUPTDÜSE 135	MAIN JET 135	X
4	570.31.523.140	HAUPTDÜSE 140	MAIN JET 140	X
4	570.31.523.145	HAUPTDÜSE 145	MAIN JET 145	X
4	570.31.523.150	HAUPTDÜSE 150	MAIN JET 150	X
5	151.31.123.055	DÜSE 55	JET 55	X
5	151.31.123.050	DÜSE 50	JET 50	1
5	151.31.123.045	DÜSE 45	JET 45	X
5	151.31.123.038	DÜSE 38	JET 38	X
6	570.31.551.045	STARTDÜSE 45 LUFTLÖCHER UNTEN	STARTING JET 45 AIR HOLE BELOW	1
6	570.31.551.050	STARTDÜSE 50	STARTING JET 50	X
6	570.31.551.055	STARTDÜSE 55	STARTING JET 55	X
7	570.31.566.033	BESCHLEUNIGERDÜSE 33	ACCELERATING JET 33	1
8	572.31.120.300	NADELVENTIL 300	NEEDLE VALVE 300	1
9	570.31.509.000	SCHWIMMER 8,5 GRAMM	FLOAT 8,5 GRAMME	1
9	583.31.509.000	SCHWIMMER 6,5 GRAMM	FLOAT 6,5 GRAMME	X
10	570.31.524.000	SK.SCHRAUBE M 5X16	HEXAGON NUT M 5X16	2
11	520.31.138.000	GUMMITÜLLE	RUBBER SLEEVE	1
12	580.31.528.000	STÜTZHÜLSE M6X0,75 SW=10	SUPPORT BUSHING M6X0,75 WS=10	1
13	572.31.127.000	VERGASERDECKEL	CARBURETOR COVER	1
15	584.31.024.000	ROHRBOGEN F.VERG. 400LC4-E '97	TUBE F.CARBURETOR 400LC4-E '97	1
18	570.31.571.000	STIFT 2,5X16	STUD 2,5X16	1
19	570.31.530.000	SCHIEBERFEDER	SLIDING SPRING	1
20	570.31.532.000	HALTEPLÄTTCHEN	RETAINING PLATE	1
21	520.31.126.000	SK.MUTTER M6X0,75 DIN0439	HEXAGON NUT M6X0,75 DIN0439	1
24	570.31.570.000	FEDER	SPRING	1
25	570.31.569.000	PUMPENHEBEL	PUMP LEVER	1
27	570.31.525.000	STELLSCHRAUBE M6X0,75	ADJUSTMENT SCREW M6X0,75	1
28	572.31.155.000	VERSCHRAUBUNG	PLUG	1
29	572.31.153.000	FEDER	SPRING	1

* = NEUTEIL / NEW PART

X = NACH BEDARF / AS REQUIRED

ACHTUNG !!!
Vor dem Einbau des Vergasers, Bedüsung kontrollieren.
CAUTION !!!
Before mounting the carburetor, check the jetting.

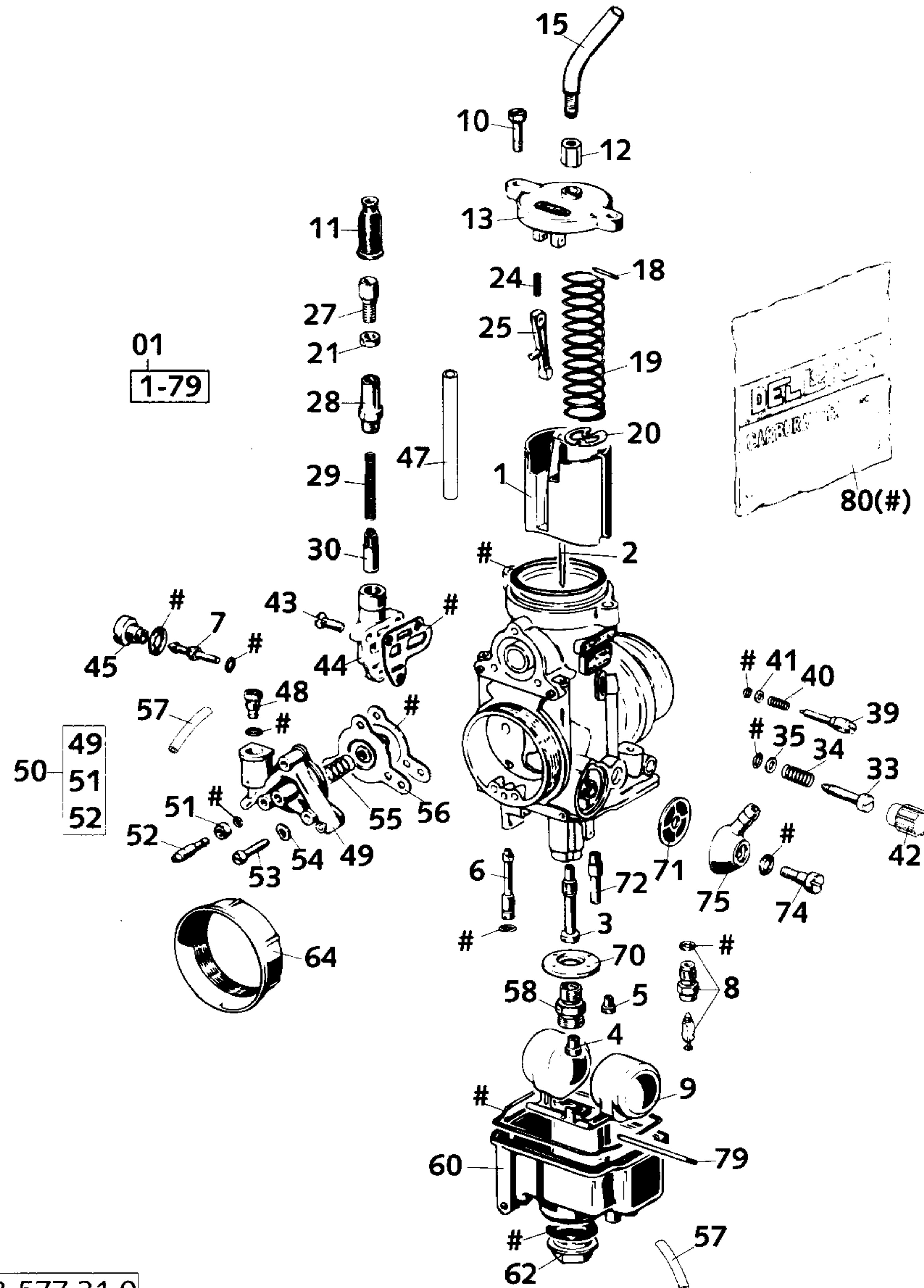

FIG	TEILNR/PARTNR	BEZEICHNUNG	DESCRIPTION	QTY
30	570.31.549.000	STARTKOLBEN	STARTING DEVICE	1
33	570.31.519.000	STELLSCHRAUBE M5	ADJUSTMENT SCREW M5	1
34	520.31.116.000	FEDER	SPRING	1
35	570.31.573.000	SCHEIBE 5,1 X 8 X 0,8	WASHER 5,1 X 8 X 0,8	1
39	570.31.517.000	GEMISCHREG.SCHRAUBE M7X0,75	MIXTURE REGULAT.SCREW M7X0,75	1
40	570.31.515.000	FEDER LUFTREG.SCHRAUBE	SPRING AIR ADJUST.SCREW	1
41	570.31.572.000	SCHEIBE 3,3 X 5,8 X 0,5	WASHER 3,3 X 5,8 X 0,5	1
42	570.31.519.100	RÄNDELKAPPE KUNSTSTOFF	KNURLED CAP PLASTIC	1
43	0964 040143	LINSENSCHRAUBE DIN0964-M 4X14	OVAL HEAD SCREW DIN0964-M 4X14	3
44	572.31.150.100	KALTSTARTVERGASERGEHÄUSE 4T	START.DEVICE BODY 4S	1
45	570.31.567.000	DÜSENHALTER	JET HOLDER	1
47	583.31.029.051	SCHIEBERANSCHLAG L=51MM	SLIDE STOP L=51MM	X
48	570.31.565.000	ENTLÜFTUNGSVENTIL	BLEEDER VALVE	1
50	572.31.160.044	PUMPENGEHÄUSE KPL.	PUMP HOUSING CPL.	1
53	0084 040203	ZYL.SCHRAUBE DIN0084-M 4X20 A	CYL.SCREW DIN0084-M 4X20 A	3
54	0137 040003	FEDERSCHEIBE DIN0137-B 4	SPRING WASHER DIN0137-B 4	3
55	570.31.559.000	FEDER	SPRING	1
56	570.31.557.000	MEMBRANE	DIAPHRAGM	1
57	520.31.137.001	PVC-SCHLAUCH 3 X 5 MM	PVC-HOSE 3 X 6 MM	0,6
58	570.31.522.000	DÜSENSTOCK	MAIN JET HOLDER	1
60	570.31.511.100	SCHWIMMERGEHÄUSE MIT ÜBERLAUFR	FLOAT CHAMBER WITH RUN OVER T.	1
62	570.31.514.000	VERSCHLUSSSCHRAUBE M12X1	PLUG M12X1	1
64	577.31.040.000	ANSAUGTRICHTER FÜR PHM 38 ND	INTAKE TRUMPET FOR PHM 38 ND	1
70	501.31.174.000	PRALLBLECH	COVER	1
71	151.31.112.000	KRAFTSTOFFILTER	FUEL FILTER	1
72	570.31.556.000	RÜCKSCHLAGVENTIL	REBOUND VALVE	1
74	0933 060163	SK.SCHRAUBE DIN0933-M 6X16	HH SCREW DIN0933-M 6X16	1
75	570.31.513.000	SCHLAUCHANSCHLUSS	HOSE CONNECTOR	1
79	570.31.508.000	STIFT 2 X 47	STUD 2 X 47	1
80	577.31.099.000	DICHTUNGSSATZ PHM 38 ND	GASKET SET PHM 38 ND	1

ACHTUNG !!!
Vor dem Einbau des Vergasers, Bedüsung kontrollieren.
CAUTION !!!
Before mounting the carburetor, check the jetting.

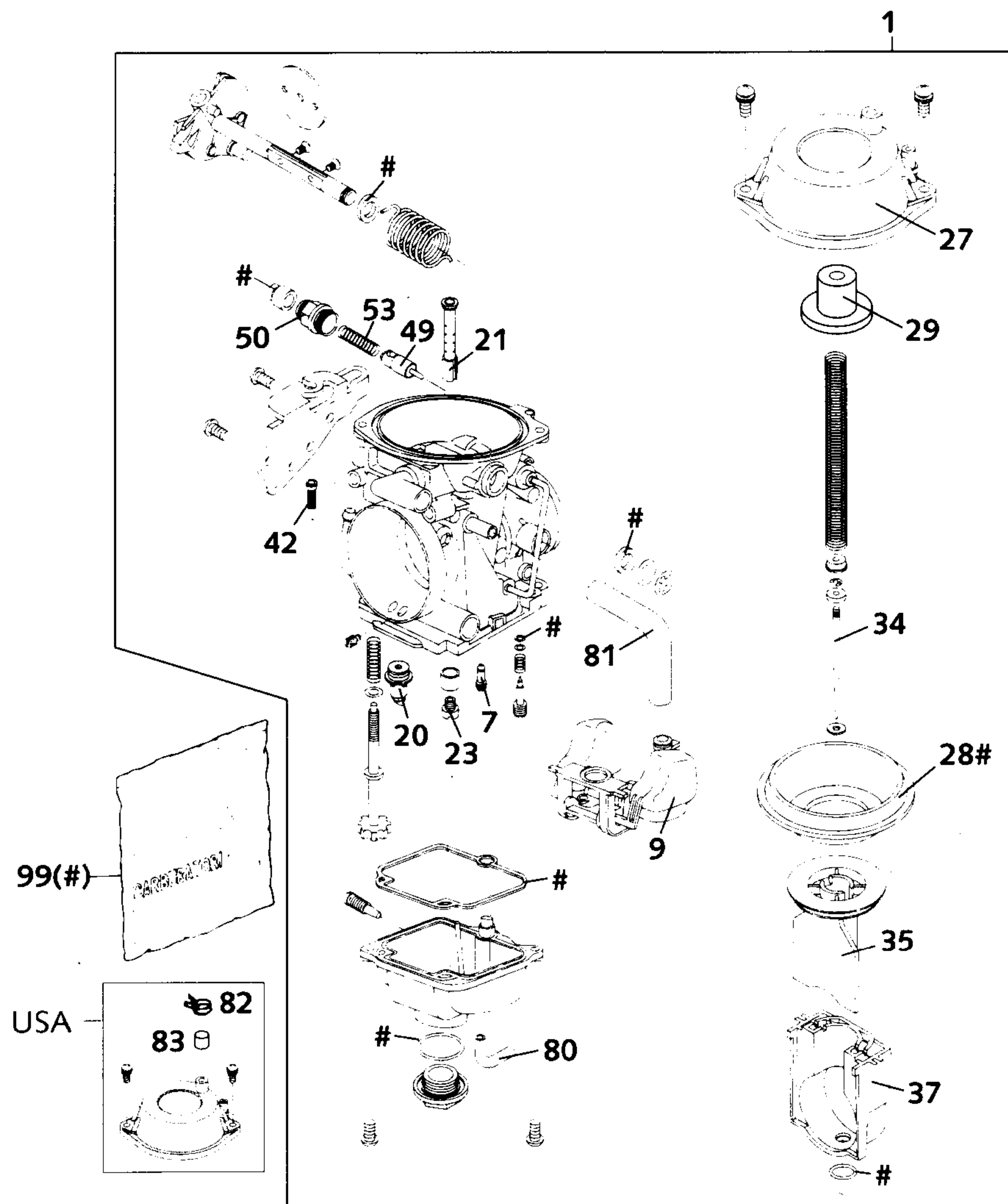

FIG	TEILNR/PARTNR	BEZEICHNUNG	DESCRIPTION	QTY
1	584.31.001.400	VERGASER MIKUNI BST40-225 '98	CARBURETOR MIKUNI BST40-225'98	1
7	584.31.007.045	LEERLAUFDÜSE 45	IDLING JET 45	1
9	584.31.009.000	SCHWIMMER 6,1 GRAMM MIKUNI	FLOAT 6,1 GRAMM MIKUNI	1
20	584.31.020.000	NADELVENTIL MESSING 2,8MM	NEEDLE VALVE 2,8MM	1
21	584.31.021.689	NADEL DÜSE 689 X-6	NEEDLE JET 689 X-6	1
23	584.31.023.140	HAUPTDÜSE 140	MAIN JET 140	X
23	584.31.023.142	HAUPTDÜSE 142,5	MAIN JET 142,5	1
23	584.31.023.145	HAUPTDÜSE 145	MAIN JET 145	1
23*	584.31.023.147	HAUPTDÜSE 147,5	MAIN JET 147,5	X
23*	584.31.023.150	HAUPTDÜSE 150	MAIN JET 150	X
23*	584.31.023.152	HAUPTDÜSE 152,5	MAIN JET 152,5	X
23*	584.31.023.155	HAUPTDÜSE 155	MAIN JET 155	X
23*	584.31.023.157	HAUPTDÜSE 157,5	MAIN JET 157,5	X
23*	584.31.023.160	HAUPTDÜSE 160	MAIN JET 160	X
27	584.31.027.000	MEMBRANDECKEL MIKUNI	DIAPHRAGM COVER MIKUNI	1
28	584.31.028.000	MEMBRAN FÜR GASSCHIEBER MIKUNI	DIAPHRAGM FOR THROTTLE VALVE	1
29	583.31.029.017	SCHIEBERANSCHLAG L=17MM	SLIDE STOP L=17MM MIKUNI	X
34	584.31.034.6G5	DÜSENNADEL 6G5	JET NEEDLE 6G5	1
35	584.31.035.000	GASSCHIEBER „1“	THROTTLE VALVE „1“	1
37	584.31.037.000	GASSCHIEBERFÜHRUNG KUNSTSTOFF	THROTTLE VALVE GUIDE PLASTIC	1
42	584.31.042.000	KRAFTSTOFFSIEB MIKUNI	FUEL SCREEN MIKUNI	1
49	584.31.049.000	STARTKOLBEN MIKUNI	STARTING PISTON MIKUNI	1
50	584.31.050.000	VERSCHRAUBUNG M12 STARTSYSTEM	SCREW M12 STARTSYSTEMN	1
53	584.31.053.000	FEDER 22,5MM FÜR STARTKOLBEN	SPRING 22,5MM FOR START.PISTON	1
80	520.31.137.001	PVC-SCHLAUCH 3 X 5 MM	PVC-HOSE 3 X 6 MM	0,5
81	544.35.024.001	ND-SCHLAUCH ID 7,5 PER METER	HOSE ID 7,5 PER METER	0,5
82	580.31.005.000	YDNAC KLAMMER 10128 12MM	CLAMP YDNAC 10128 12MM	1
83	579.31.001.010	VERSCHL.KAPPE F. EPC-ANSCHLUSS	PLUG CAP FOR EPC CONNECTION	1
99	584.31.099.000	DICHTUNGSSATZ MIKUNI BST40-225	GASKET SET MIKUNI BST40-225	1

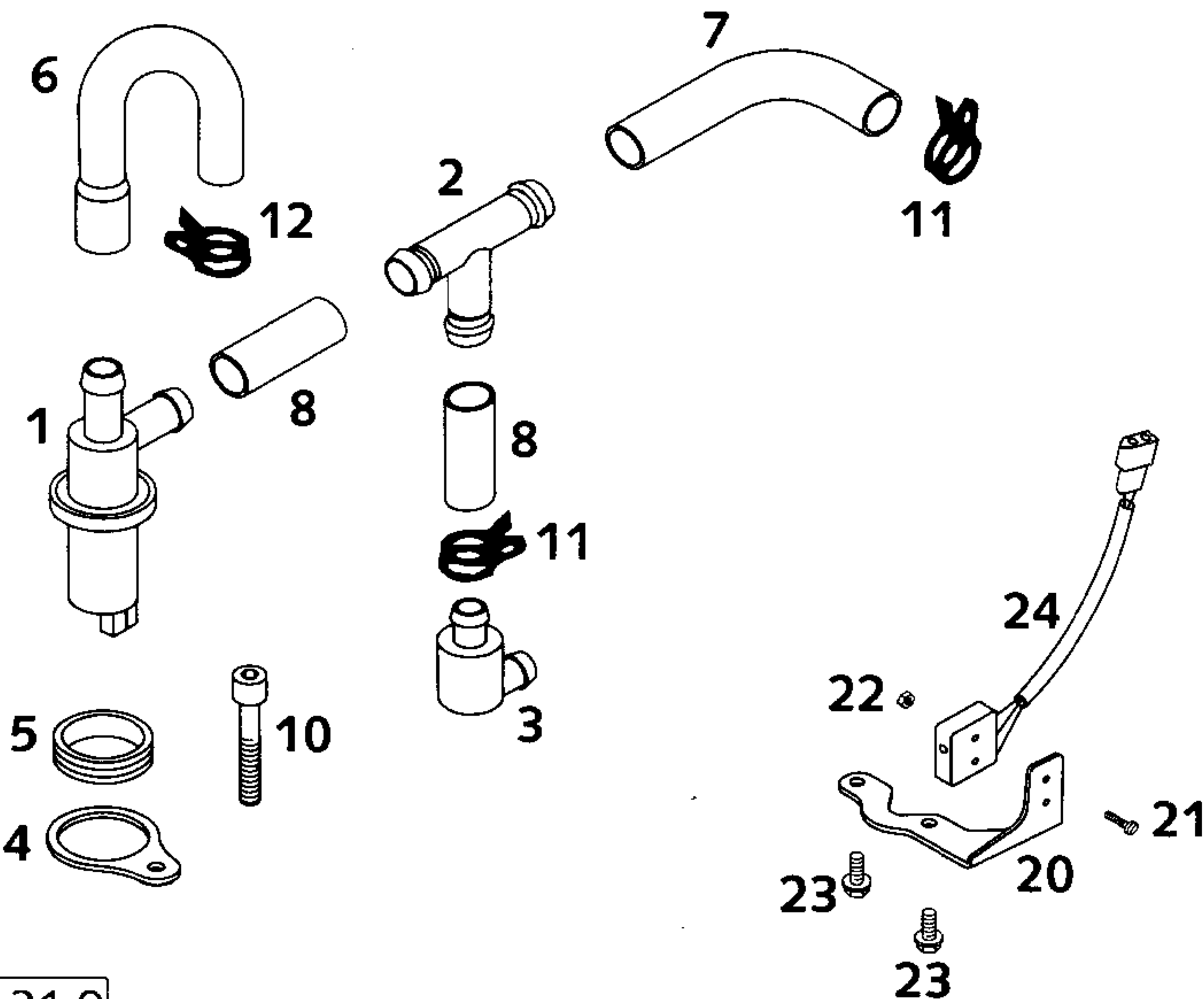
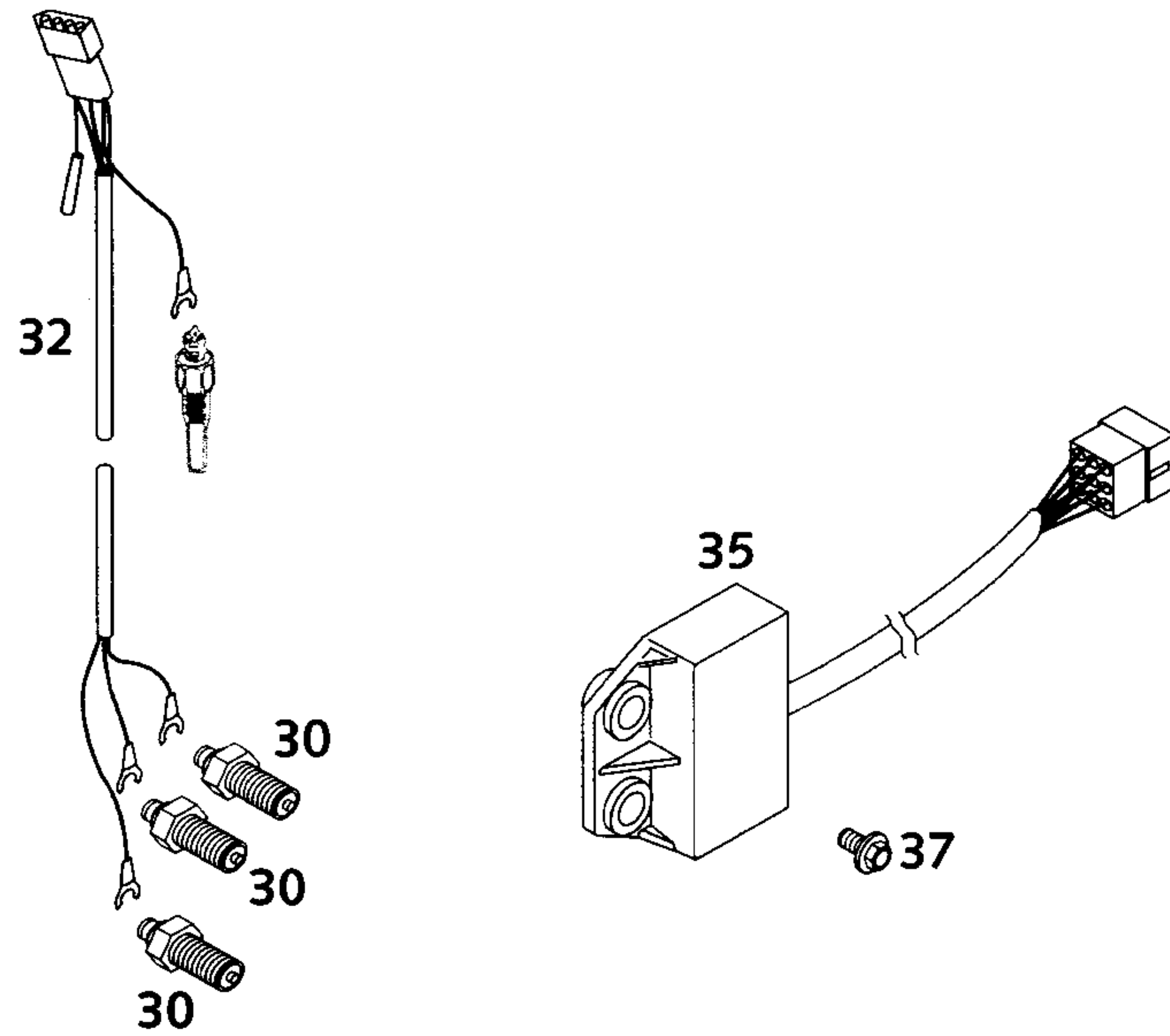

FIG	TEILNR/PARTNR	BEZEICHNUNG	DESCRIPTION	QTY
1	584.31.067.000	MAGNETVENTIL PIRBURG F.EPC '98	MAGNETIC VALVE PIRBURG EPC '98	1
2	584.31.072.000	T-STÜCK 12MM LC4 '98	T-CONNECTION 12MM LC4 '98	1
3	584.31.070.000	LUFTFILTER LC4 FÜR EPC '98	AIR FILTER LC4 '98	1
4	584.31.069.000	HALTEBLECH F. MAGNETVENTIL '98	BRACKET FOR MAGNETIC VALVE '98	1
5	546.35.022.000	TÜLLE-STEUERKOPF	SLEEVE FOR STEERING HEAD	1
6	584.31.071.000	UNTERDRUCKSCH. FÜR MAGNETV.'98	VACUUM HOSE FOR MAGNETIC V.'98	1
7	584.31.097.000	WINKELSCHL.T-STÜCK-VERGASER'98	ANGULAR HOSE T-CON.-CARBURETOR	1
8	584.31.097.100	SCHLAUCH 12MM T-STK.-FILTER'98	TUBE 12MM T-CON.-FILTER '98	2
10	0912 060404	ISK.SCHRAUBE DIN0912-M 6X40	AH SCREW DIN0912-M 6X40	1
11	584.31.082.000	YDNAC-KLAMMER 15MM '98	YDNAC-CLAMP 15MM '98	2
12	584.31.082.100	YDNAC-KLAMMER 16MM '98	YDNAC-CLAMP 16MM '98	1
20	584.31.080.000	HALTEBLECH FÜR ENDSCHALTER '98	BRACKET FOR ENDSWITCH '98	1
21	0084 020103	ZYL.SCHRAUBE DIN0084-M 2X10	CYL.HEAD SCREW DIN0084-M 2X10	2
22	0934 020003	SK.MUTTER DIN0934-M 2	HH NUT DIN0934-M 2	2
23	0015 050123	SK.BUNDSCHRAUBE M 5X12 SW=8	HH COLLAR SCREW M 5X12 WS=8	2
24	584.31.065.100	MICROSCHALTER LC4 '98	MICRO SWITCH LC4 '98	1
30	580.11.081.100	KONTAKTSCHRAUBE M10 STAHL '98	CONTACT SCREW M10 STEEL '98	3
32	584.11.085.000	KABELSTRANG EPC FÜR MOTOR LC4	WIRING HARN. EPC F. ENGINE LC4	1
35	584.31.063.000	STEUERGERÄT FÜR EPC '98 640 LC4-E	CONTROL UNIT FOR EPC '98 640 LC4-E	1
35	584.31.063.100	STEUERGERÄT FÜR EPC DUKE '99 640 DUKE	CONTROL UNIT FOR EPC DUKE '99 640 DUKE	1
37	0014 060103	SK.BUNDSCHRAUBE M 6X10 SW=8	HH COLLAR SCREW M 6X10 WS=8	2

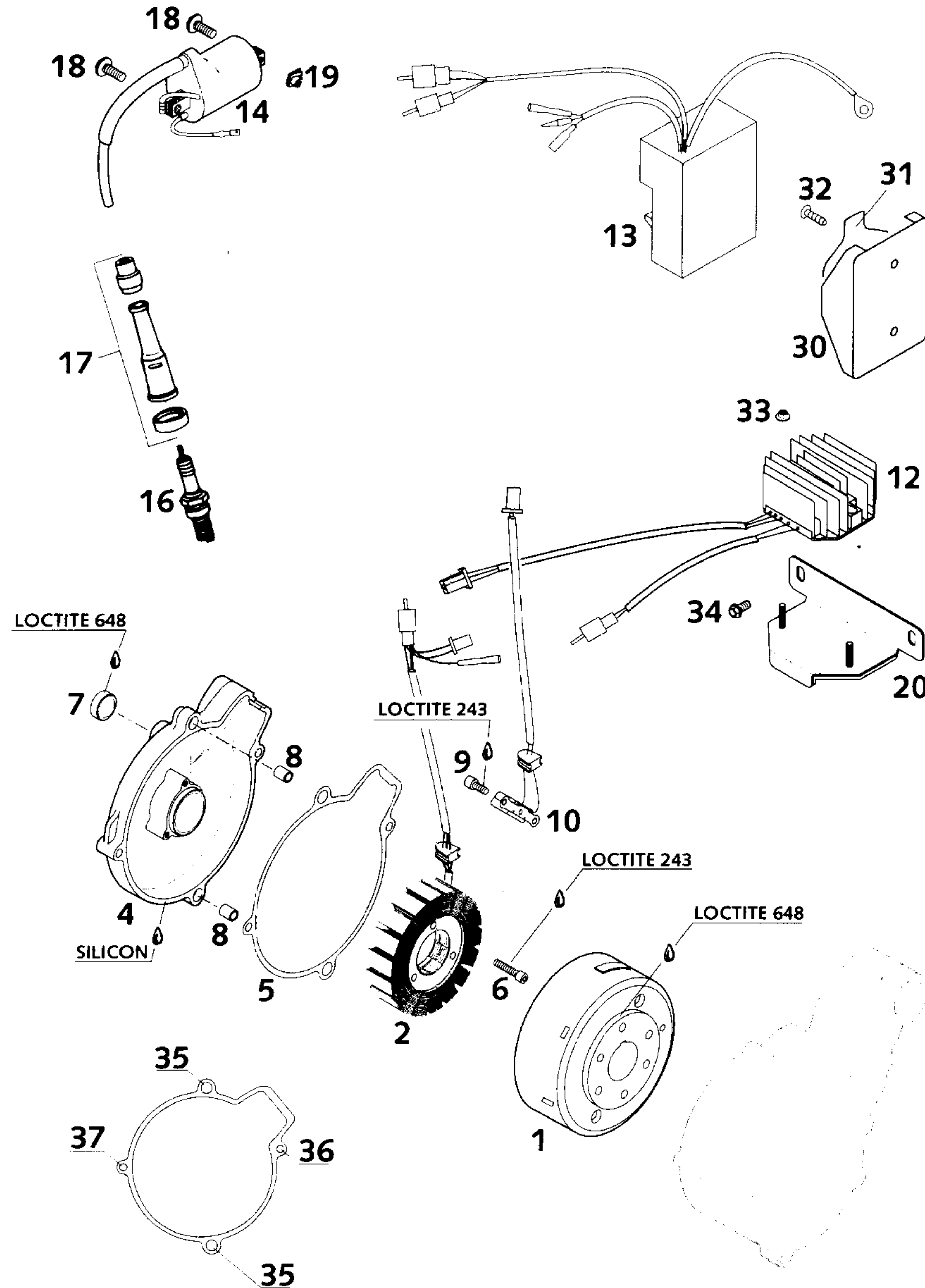

FIG	TEILNR/PARTNR	BEZEICHNUNG	DESCRIPTION	QTY
1	584.39.005.100	ROTOR KOKUSAN LOSE GP9128 '97	FLYWHEEL KOKUSAN GP9128 '97	1
2	584.39.004.000	STATOR KOKUSAN LOSE '96	STATOR KOKUSAN LOOSE '96	1
4	584.30.002.144	ZÜNDUNGSDECKEL KPL. LC4-E '97	IGNITION COVER CPL. LC4-E '97	1
5	584.30.040.000	ZÜNDUNGSDECKELDICHTUNG '96	IGNITION COVER GASKET '96	1
6	0912 050253	ISK.SCHRAUBE DIN0912-M 5X25	AH SCREW DIN0912-M 5X25	3
7	584.30.095.000	ÖLSCHAUGLAS GW 20-7	INSPECTION GLASS GW 20-7 NBR	1
8	490.30.090.000	PASSHÜLSE 9,8 X 7 X 10	DOWEL 9,8 X 7 X 10	2
9	0912 050083	ISK.SCHRAUBE DIN0912-M 5X 8	AH SCREW DIN0912-M 5X 8	2
10	584.39.034.000	IMPULSGEBER	PULSER COIL	1
12	584.11.034.100	REGLER-GLEICHRICHTER 12V '97	VOLT.REGULATOR-RECTIFIER 12V	1
13	584.39.031.100	DIGITALBOX CDI CB7428 '97 400 LC4-E	DIGITALBOX CDI CB7428 '97 400 LC4-E	1
13	584.39.031.200	DIGITALBOX CDI CB7459 95ROZ'99 640 LC4-E	DIGITALBOX CDI CB7459 95ROZ'99 640 LC4-E	1
13	584.39.031.300	DIGITALB.CDI CB7477 80ROZ 2000 640 LC4-E	DIGITALB.CDI CB7481 80ROZ 2000 640 LC4-E	X
14	584.39.006.000	ZÜNDSPULE IG3826 KOKUSAN '96	IGNITIONCOIL IG3826 KOKUSAN'96	1
16	584.39.093.009	ZÜNDKERZE NGK DPR8EA-9	SPARK PLUG NGK DPR8EA-9	1
17	580.31.010.000	ZÜNDKERZENSTECKER SD05F NGK	SPARK PLUG CONNECT.SD 05FG NGK	1
18	0014 060153	SK.BUNDSCHRAUBE M 6X15 SW=8	HH COLLAR SCREW M 6X15 WS=8	2
19	502.35.033.300	KLIPS-MUTTERNHALTER M6 KP142	SNAP-NUT HOLDER M6 KP142	2
20	584.11.055.100	BATTERIEHALTEBÜ. LC4-E/DUKE'97	BATTERY BRACKET LC4-E/DUKE'97	1
30	584.39.030.100	GUMMIHALTER FÜR DIGITALBOX '97	RUBBER BRACKET FOR CDI '97	1
31	584.39.030.150	HALTEBLECH FÜR GUMMIHALTER '97	SUPPORT FOR RUBBER BRACKET '97	1
32	0016 055163	PLASTITE SCHRAUBE 5,5X16	SPECIAL SCREW Z 5,5X16	2
33	565.09.064.100	STOVER-FLANSCHMUTTER M6 10.9	SELF LOCKING NUT M6 10.9	2
34	0015 060103	SK.BUNDSCHRAUBE M 6X10 SW=8	HH COLLAR SCREW M 6X10 WS=8	2
35	0015 060303	SK.BUNDSCHRAUBE M 6X30 SW=8	HH COLLAR SCREW M 6X30 WS=8	2
36	0015 060803	SK.BUNDSCHRAUBE M 6X80 SW=8	HH COLLAR SCREW M 6X80 WS=8	1
37	0015 060253	SK.BUNDSCHRAUBE M 6X25 SW=8	HH COLLAR SCREW M 6X25 WS=8	1

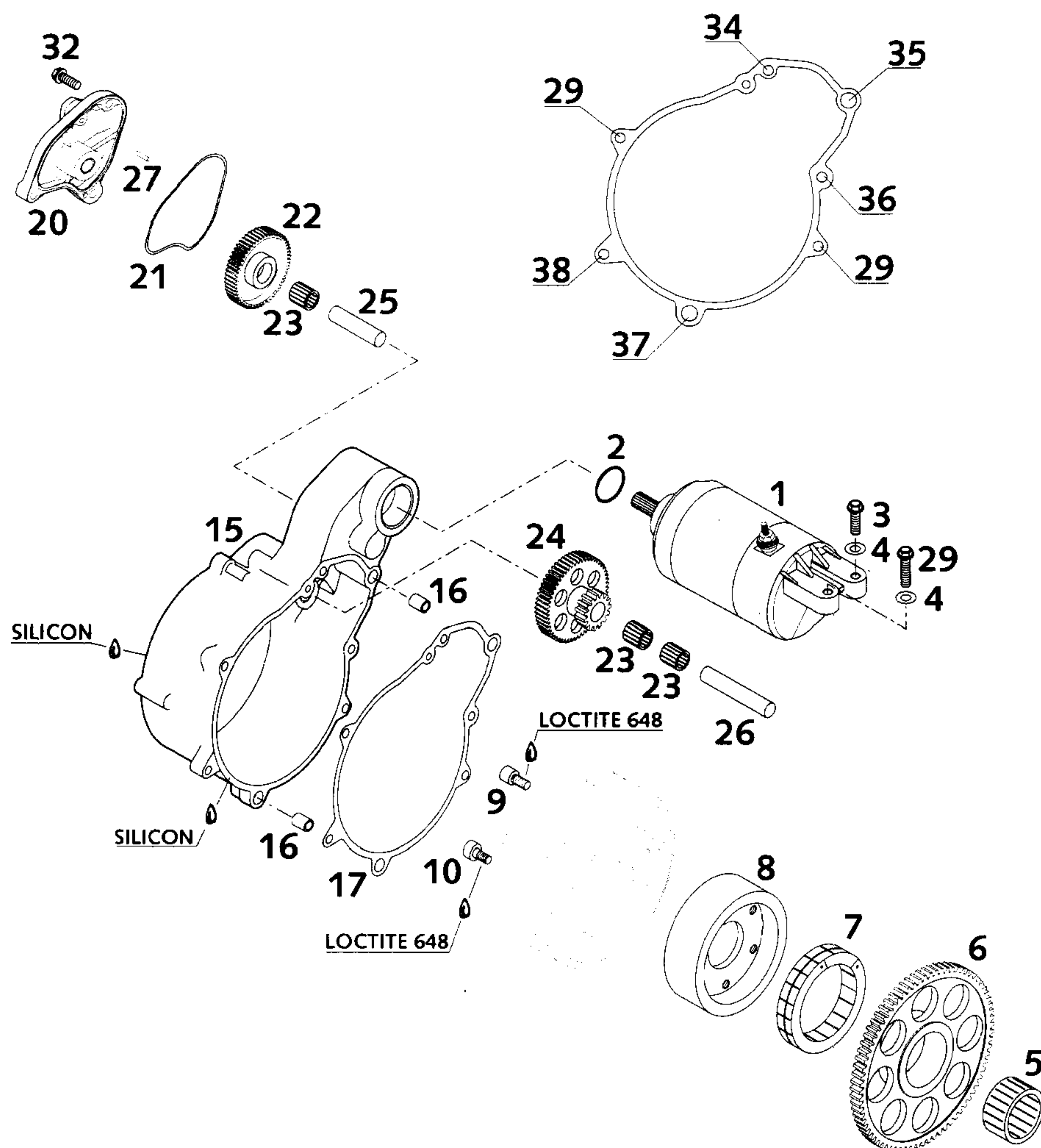

FIG	TEILNR/PARTNR	BEZEICHNUNG	DESCRIPTION	QTY
1	584.40.001.000	E-STARTERMOTOR KPL. LC4-E	E-STARTER ENGINE CPL. LC4-E	1
2	0770 250030	O-RING 25,00X3,00 NBR 70	O-RING 25,00X3,00 NBR 70	1
3	0015 060203	SK.BUNDSCHRAUBE M 6X20 SW=8	HH COLLAR SCREW M 6X20 WS=8	1
4	0125 060003	UNTERLEGSCHIEBE DIN0125-A 6,4	WASHER DIN0125-A 6,4	2
5	584.40.090.100	NADELKLANZ K30 X 37 X 18 A	NEEDLE BEARING K30 X 37 X 18	1
6	584.40.020.079	FREILAUFZAHNRAD 79-Z	FREE-WHEEL-GEAR 79-T	1
7	584.40.026.000	FREILAUF FWD 332008 BLS	FREE-WHEEL FWD 332008 BLS	1
8	584.40.025.000	FREILAUFNABE	FREEWHEEL HUB	1
9	0912 060121	ISK.SCHRAUBE DIN0912-M 6X12	AH SCREW DIN0912-M 6X12	4
10	584.40.098.000	ISK-SCHRAUBE M6X12,5 M. ANSATZ	AH CENTERING SCREW M6X12,5	2
15	584.40.010.100	STARTERFLANSCH SCHWARZ '97	STARTER FLANGE BLACK '97	1
16	490.30.090.000	PASSHÜLSE 9,8 X 7 X 10	DOWEL 9,8 X 7 X 10	2
17	584.40.042.000	STARTERFLANSCHDICHTUNG	STARTER FLANGE GASKET	1
20	584.40.011.100	STARTERDECKEL SCHWARZ '97	STARTER COVER BLACK '97	1
21	584.40.011.050	FORMRING F.STARTERDECKEL NBR70	FORM RING F.STARTERCOVER NBR70	1
22	584.40.022.000	ZWISCHENZAHNRAD 52-Z	INTERMEDIATE GEAR 52-T	1
23	584.40.090.000	NADELKLANZ K10 X 13 X 13 TN	NEEDLE BEARING K10 X 13 X 13	3
24	584.40.021.018	DOPPELZAHNRAD 55-Z/18-Z	REDUCTION GEAR 55-T/18-Z	1
25	584.40.028.000	LAGERBOLZEN 10 X 38,4	BEARING BOLT 10 X 38,4	1
26	584.40.029.000	LAGERBOLZEN 10 X 54	BEARING BOLT 10 X 54	1
27	0402 040780	NADELROLLE DIN5402 NRB 4X 7,8	NEEDLEROLL. DIN5402 NBR 4X 7,8	2
29	0015 060253	SK.BUNDSCHRAUBE M 6X25 SW=8	HH COLLAR SCREW M 6X25 WS=8	3
32	0015 060163	SK.BUNDSCHRAUBE M 6X16 SW=8	HH COLLAR SCREW M 6X16 WS=8	1
34	0015 060453	SK.BUNDSCHRAUBE M 6X45 SW=8	HH COLLAR SCREW M 6X45 WS=8	1
35	0015 060503	SK.BUNDSCHRAUBE M 6X50 SW=8	HH COLLAR SCREW M 6X50 WS=8	1
36	0015 060803	SK.BUNDSCHRAUBE M 6X80 SW=8	HH COLLAR SCREW M 6X80 WS=8	1
37	0015 060303	SK.BUNDSCHRAUBE M 6X30 SW=8	HH COLLAR SCREW M 6X30 WS=8	1
38	0015 060953	SK.BUNDSCHRAUBE M 6X95 SW=8	HH COLLAR SCREW M 6X95 WS=8	1

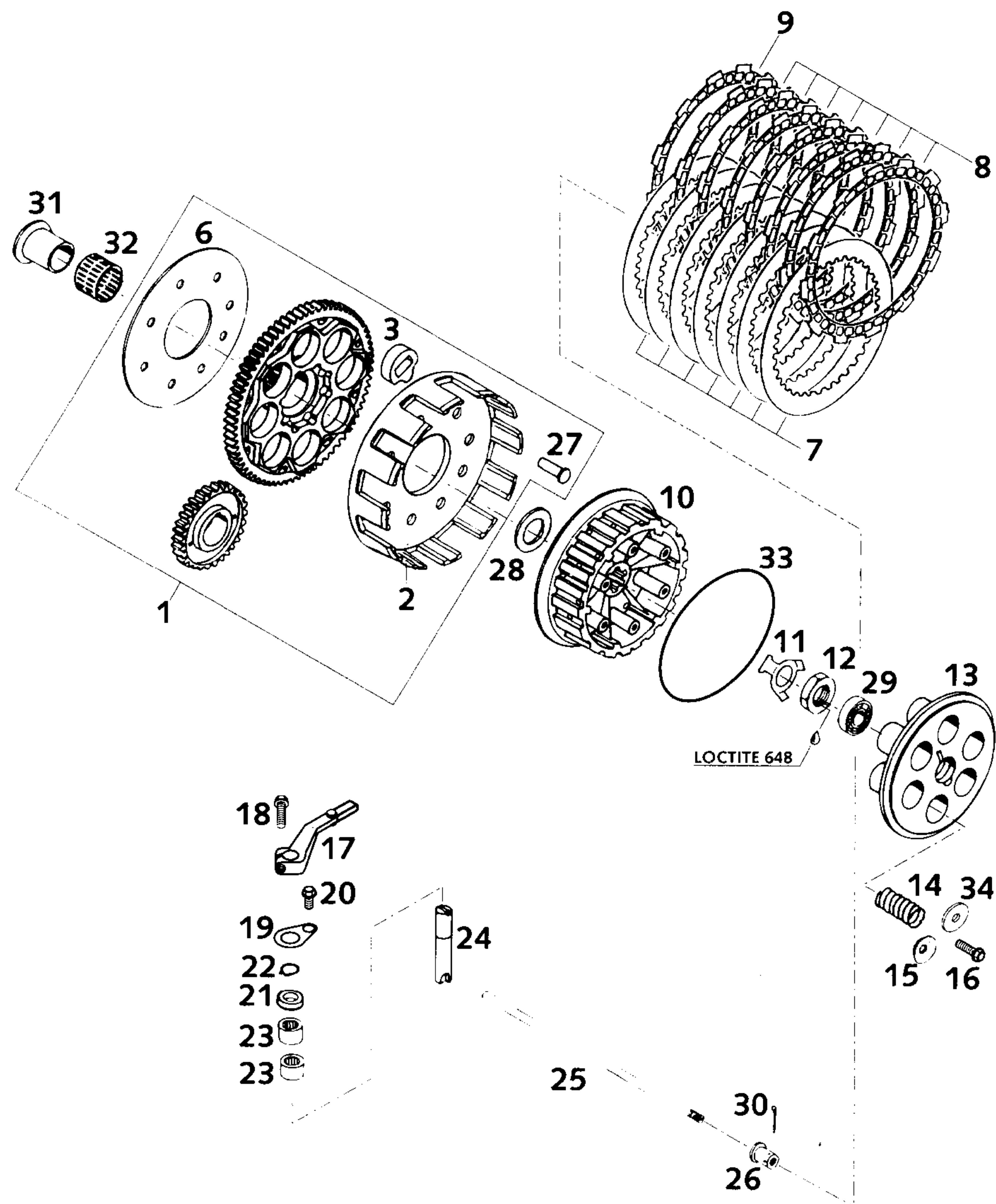

FIG	TEILNR/PARTNR	BEZEICHNUNG	DESCRIPTION	QTY
1	583.32.001.081	KUPPLUNGSKORB 81-Z M.PRIM.30-Z	OUTER CL.HUB 81-T W.PRIM.30-T	1
2	583.32.001.000	KUPPLUNGSKORB LOSE D=160MM '94	OUTER CL.HUB LOOSE D=160MM '94	1
3	583.32.026.000	DÄMPFUNGSELEMENT '94	DAMPING ELEMENT '94	8
6	583.32.028.000	HALTEBLECH 57 X 132 X 1,5 '94	BRACKET 57 X 132 X 1,5 '94	1
7	583.32.112.000	STAHLLELLE 1,5 MM LC4'94	STEEL DISK 1,5 MM LC4'94	7
8	583.32.011.200	BELAGLELLE 2,7 MM CR-087 '99	LINING DISK 2,7 MM CR-087 '99	7
9	583.32.111.200	BELAGLELLE 2,7MM AUSGEDREHT'99	LINING DISK 2,7 MM SPECIAL '99	1
10	583.32.002.200	MITNEHMER LC4/LC4-E '98	INNER CLUTCH HUB LC4/LC4-E '98	1
11	583.32.018.000	SICHERUNGSBLECH '94	LOCK WASHER '94	1
12	0936 181505	SK.MUTTER DIN0936-M18X1,5 RE.	HEXAGON NUT DIN0936-M18X1,5 R.	1
13	583.32.003.200	DRUCKKAPPE LC4/LC4-E '98	PRESSURE CAP LC4/LC4-E '98	1
14	583.32.080.000	KUPPLUNGSFEDER 2,8 X 37	CLUTCH SPRING 2,8 X 37	6
15	581.32.081.000	FEDERTELLER 6,2 X 20 X 3,2 400	SPRING RETAINER 6,2 X 20 X 3,2 400	6
16	0015 060203	SK.BUNDSCHRAUBE M 6X20 SW=8	HH COLLAR SCREW M 6X20 WS=8	6
17	584.32.048.044	AUSRÜCKHEBEL LC4-E '96	CLUTCH RELEASE LEVER LC4-E '96	1
18	0015 060203	SK.BUNDSCHRAUBE M 6X20 SW=8	HH COLLAR SCREW M 6X20 WS=8	1
19	584.32.044.000	HALTEBLECH FÜR AUSRÜCKUNG '96	RETAIN.PLATE CLU.RELEASE LEVER	1
20	0015 060123	SK.BUNDSCHRAUBE M 6X12 SW=8	HH COLLAR SCREW M 6X12 WS=8	1
21	545.32.093.000	NUTRING NIS 12X20X5,5	NUT RING NIS 12X20X5,5	1
22	0471 120010	SICHERUNGSRING DIN0471-12X1	CIRCLIP DIN0471-12X1	1
23	503.32.095.000	NADELLAGER HK 1212	NEEDLE BEARING HK 1212	2
24	575.32.015.000	AUSRÜCKWELLE 12 X 66 '93	DISENGAGING SHAFT 12 X 66 '93	1
25	583.32.017.000	DRUCKSTANGE 224MM LC4'94	PUSH ROD 224 MM LC4'94	1
26	583.32.032.000	AUFLAGEBOLZEN LC4'94	PRESSURE BOLT LC4'94	1
27	583.32.007.000	NIET 6 X 23 X 11,2	RIVET 6 X 23 X 11,2	8
28	575.32.013.000	STÜTZSCHEIBE 22,2X35X3 GEHÄRT.	SUPPORTWASHER 22,2X35X3 HARDE.	1
29	0625 060016	RILLENKUGELLAGER 6001.2RSR C3	GROOVED BALL BEARING 6001.2RSR	1
30	0094 020163	SPLINT DIN0094-2,0X16	PIN DIN0094-2,0X16	1
31	503.32.070.000	INNENRING MIT BUND	INNER RING WITH COLLAR	1
32	565.32.095.000	NADELKRAUZ K 26X30X22 ZW.KSE	NEEDLE BEARING K26X30X22ZW.KSE	1
33	0770 116030	O-RING 116,00X3,00 NBR 70	O-RING 116,00X3,00 NBR 70	1
34	584.32.081.000	STUFENSCHLEIBE 6,5 X 20 X 2 640	WASHER 6,5 X 20 X 2 640	6

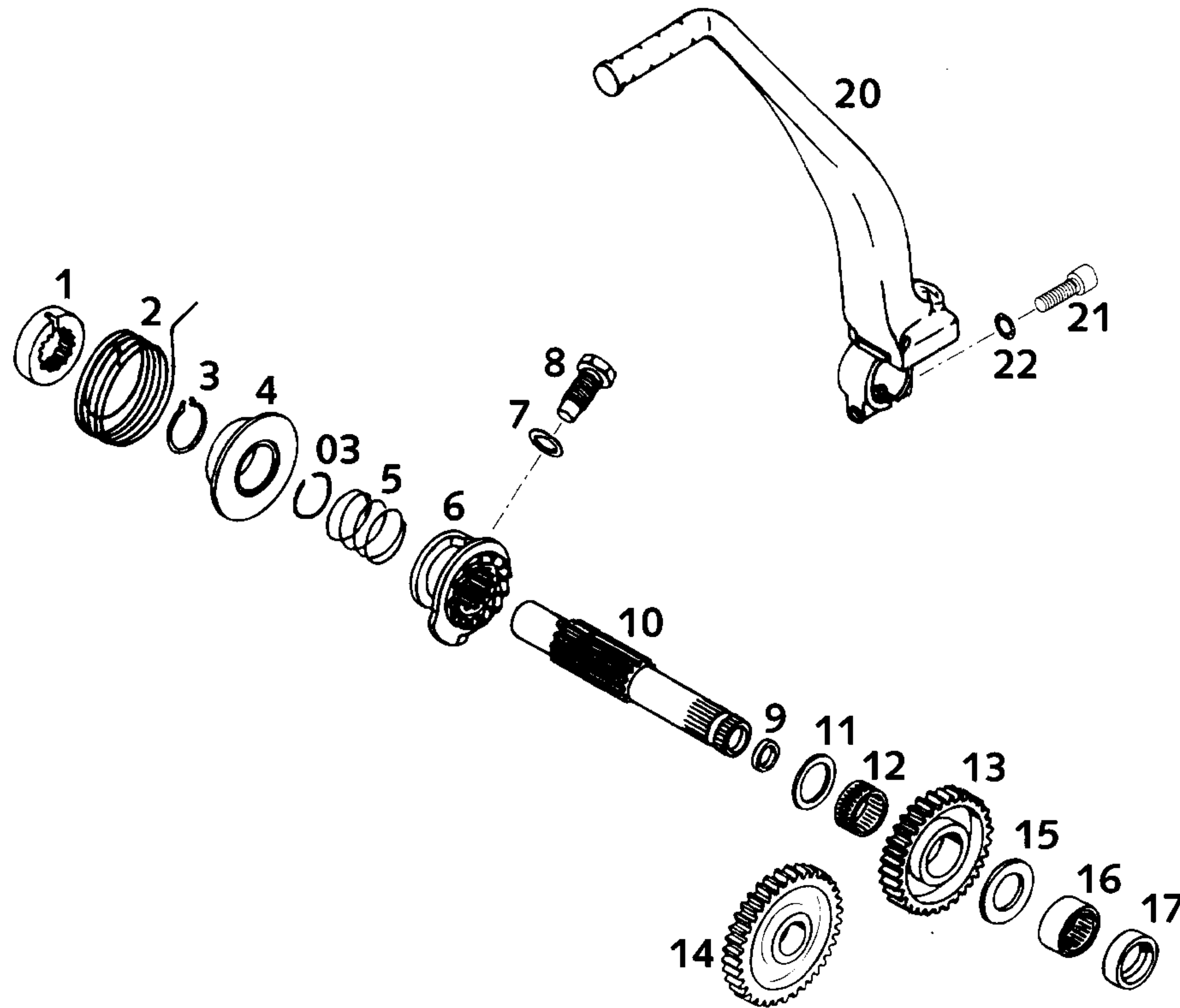

FIG	TEILNR/PARTNR	BEZEICHNUNG	DESCRIPTION	QTY
1	580.33.026.200	MITNEHMERNABE '94	DRIVING HUB '94	1
2	580.33.020.000	STARTERFEDER	KICKSTARTER SPRING	1
3	520.33.096.000	SICH.RING DIN0471-25X1,64SD	LOCK RING DIN0471-25X1,64SD	1
03	520.33.090.100	SPRENGRING 25X1,2	LOCK RING 25X1,2	1
4	580.33.037.000	FEDERFÜHRUNG	SPRING BUSHING	1
5	580.33.028.000	SPERRADFEDER 1,2 MM	RATCHET GEAR SPRING 1,2 MM	1
6	580.33.023.200	SPERRRAD 24-Z	RATCHET GEAR 24-T	1
7	580.38.022.000	CU-DICHTRING DIN7603-12X18X1,5	CU-SEAL RING DIN7603-12X18X1,5	1
8	580.33.033.000	ANSCHLAGSCHRAUBE M12X1,5	STOP SCREW M12X1,5	1
9	546.32.090.000	DICHTRING DH/GR 12X16X3	SEAL RING DH/GR 12X16X3	1
10	580.33.021.300	KICKSTARTERWELLE '94	KICKSTARTER SHAFT '94	1
11	580.33.031.000	ANLAUFSCHIEBE 22,2 X 30 X 1,5	STOP DISK 22 X 30 X 1,5	1
12	565.33.098.000	NADELKRANZ K 22 X 26 X 13 H	NEEDLE BEARING K 22 X 26 X 13H	1
13	580.33.022.700	STARTERRAD 35-Z SPERRVERZÄHNUNG 24-Z	KICKSTARTER GEAR 35-T LOCKING TOOTH 24-T	1
14	580.33.024.000	STARTERZWISCHENRAD 37-Z	INTERMEDIATE GEAR 37-T	1
15	565.32.012.000	ANLAUFSCHIEBE 22,2 X 35 X 2	STOP DISK 22,2 X 35 X 2	1
16	580.33.090.000	NADELLAGER RNA 4903	NEEDLE BEARING RNA 4903	1
17	0760 223270	WELLENDICHTRING 22X32X7 BSL	SHAFT SEAL RING 22X32X7 BSL	1
20	583.33.036.044	KICKSTARTER KPL. ALU LC4'94	KICKSTARTER CPL. ALU LC4'94	1
21*	0015 080253	SK.BUNDSCHRAUBE M 8X25 SW=10	HH COLLAR SCREW M 8X25 WS=10	1
22	360.03.014.000	SCHNORR-SICHERUNGSSCHIEBE 8MM	LOCK WASHER 8MM	1

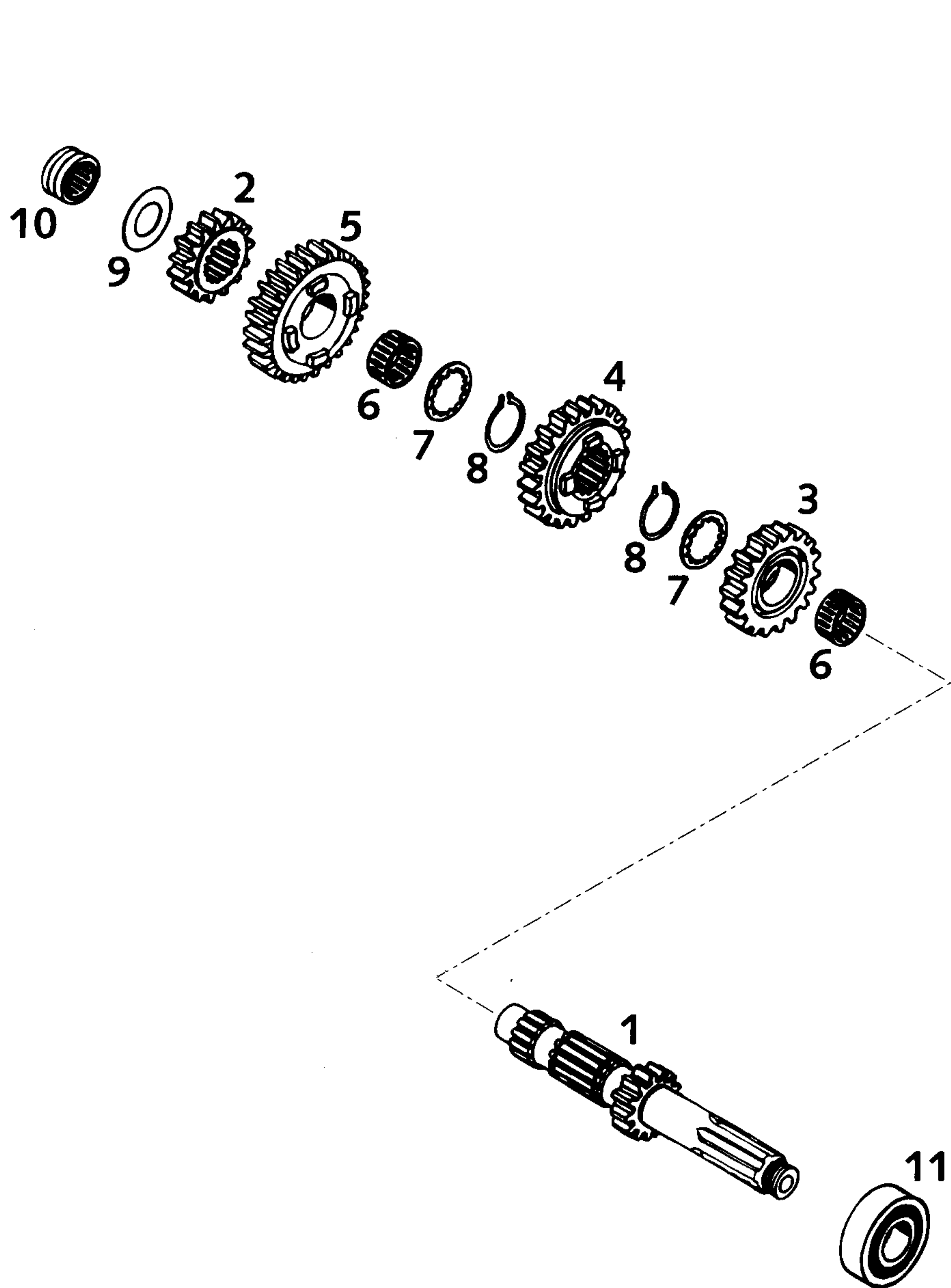
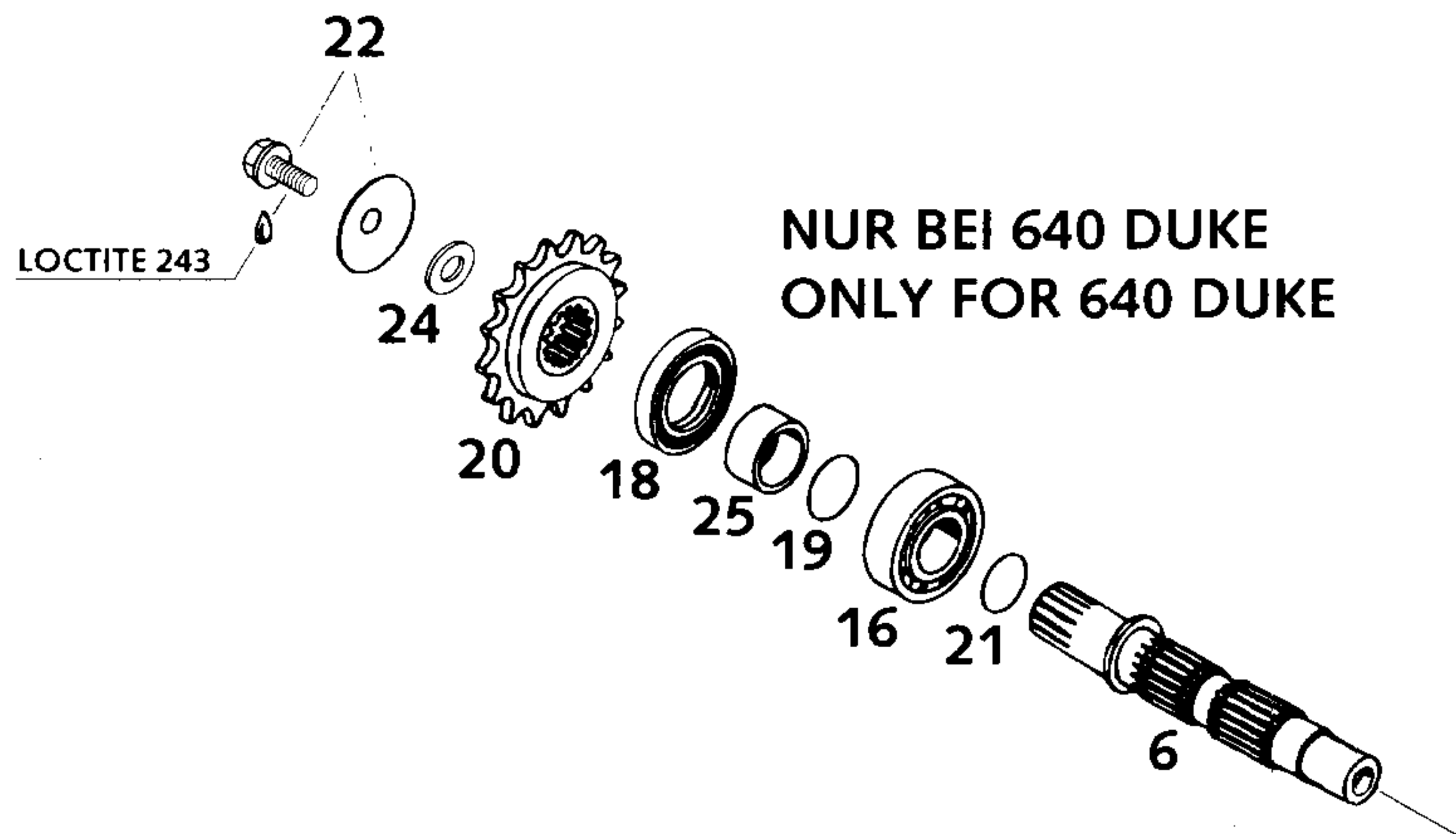
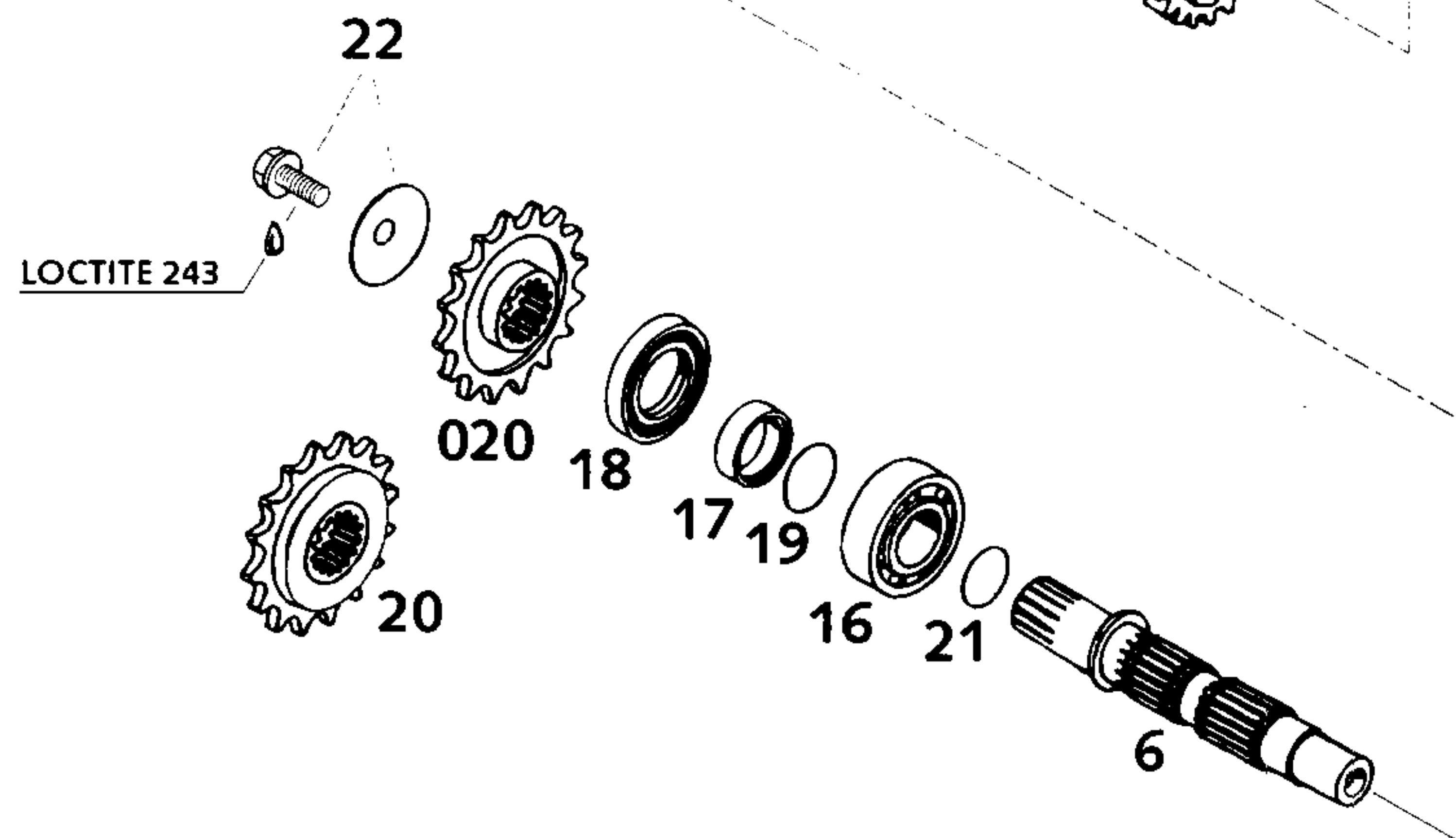
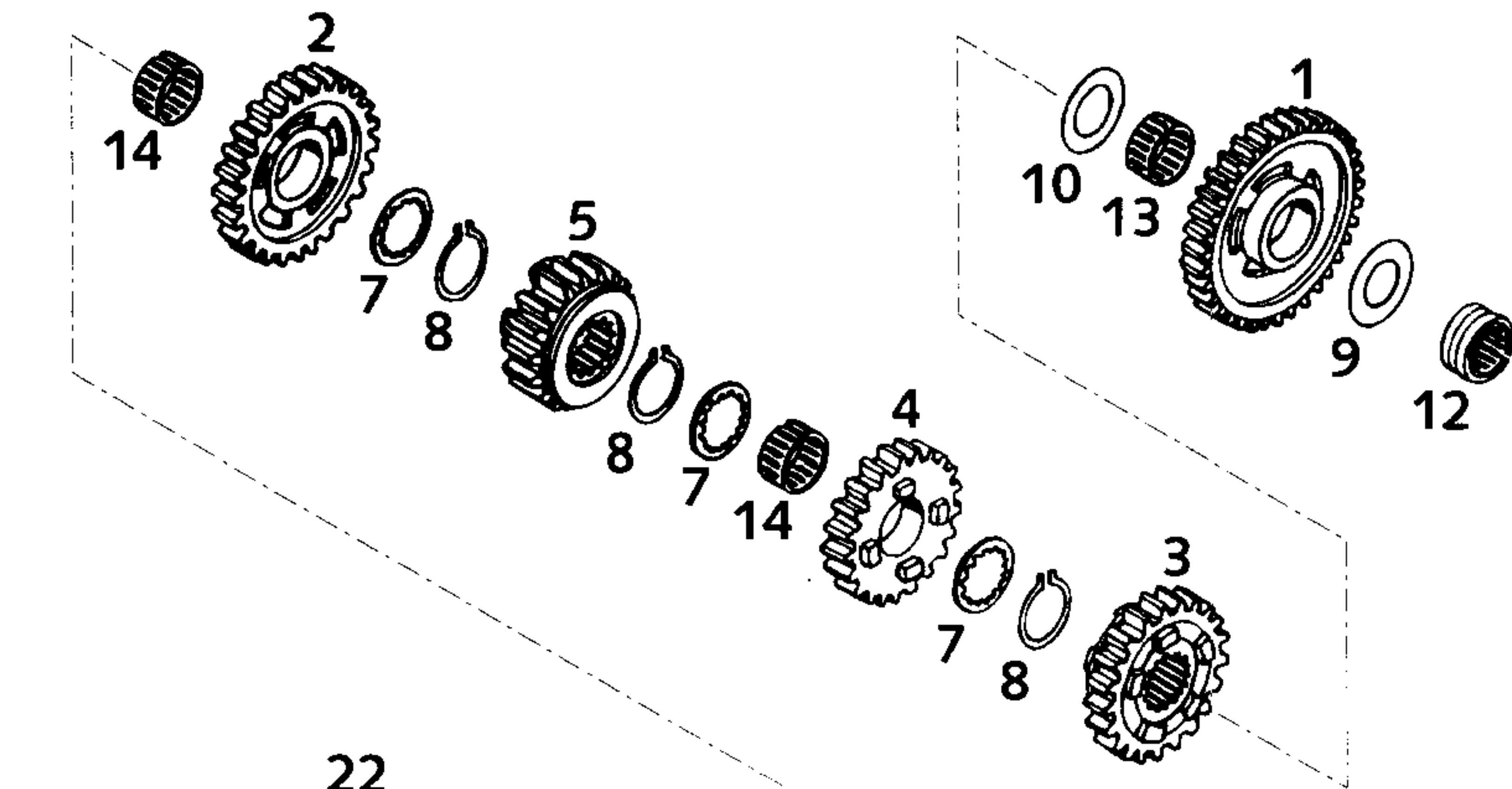

FIG	TEILNR/PARTNR	BEZEICHNUNG	DESCRIPTION	QTY
1	583.33.002.100	ANTRIEBSWELLE 14-Z '96	MAIN SHAFT 14-T '96	1
2	565.33.010.300	FESTRAD 2.G 15-Z (2G3)	SOLID GEAR 2.G 15-T (2G3)	1
3	583.33.004.002	LOSRAD 3.G 18-Z „02“	IDLER GEAR 3.G 18-T „02“	1
4	583.33.006.004	SCHIEBERAD 4.G 20-Z „04“	SLIDING GEAR 4.G 20-T „04“	1
5	583.33.008.008	LOSRAD 5.G 22-Z „08“	IDLER GEAR 5.G 22-T „08“	1
6	565.33.099.000	NADELKRANZ K22X26X13 GETEILT	NEEDLE BEAR. K22X26X13 DIVIDED	2
7	565.33.016.300	ANLAUFSCHIEBE 22,7 X 32 X 1,5	STOP DISK 22,7 X 32 X 1,5	2
8	520.33.096.000	SICH.RING DIN0471-25X1,64SD	LOCK RING DIN0471-25X1,64SD	2
9	565.33.015.000	ANLAUFSCHIEBE 20,2 X 35 X 1	STOP DISK 20,2 X 35 X 1	1
10	565.33.093.000	NADELLAGER RNA 4902 KSE	NEEDLE BEARING RNA 4902 KSE	1
11	0625 201029	RILLENKUGELLAGER 6304-22 C4	BALL BEARING 6304-22 C4 SKF	1

FIG	TEILNR/PARTNR	BEZEICHNUNG	DESCRIPTION	QTY
1	565.33.005.300	LOS RAD 1.G 35-Z (1M3)	IDLER GEAR 1.G 35-T (1M3)	1
2	583.33.113.010	LOS RAD 2.G 24-Z „10“	IDLER GEAR 2.G 24-T „10“	1
3	583.33.007.003	SCHIEBERAD 3.G 21-Z „03“	SLIDING GEAR 3.G 21-T „03“	1
4	583.33.009.005	LOS RAD 4.G 19-Z „05“	IDLER GEAR 4.G 19-T „05“	1
5	583.33.011.009	SCHIEBERAD 5.G 18-Z „09“	SLIDING GEAR 5.G 18-T „09“	1
6	583.33.003.000	ABTRIEBSWELLE	COUNTERSHAFT	1
7	565.33.016.300	ANLAUFSCHIEBE 22,7 X 32 X 1,5	STOP DISK 22,7 X 32 X 1,5	3
8	520.33.096.000	SICH.RING DIN0471-25X1,64SD	LOCK RING DIN0471-25X1,64SD	3
9	565.33.015.000	ANLAUFSCHIEBE 20,2 X 35 X 1	STOP DISK 20,2 X 35 X 1	1
10	565.33.018.300	ANLAUFSCHIEBE 22,2 X 35 X 1,5	STOP DISK 22,2 X 35 X 1,5	1
12	565.33.093.000	NADELLAGER RNA 4902 KSE	NEEDLE BEARING RNA 4902 KSE	1
13	565.33.098.000	NADELKLANZ K 22 X 26 X 13 H	NEEDLE BEARING K 22 X 26 X 13H	1
14	565.33.099.000	NADELKLANZ K22X26X13 GETEILT	NEEDLE BEAR. K22X26X13 DIVIDED	2
16	490.30.023.000	ZYLINDERROLLENLAG. NJ205 C3	CYL.ROLL BEARING NJ205 C3	1
17	580.33.017.000	DISTANZHÜLSE	SPACER BUSHING 25 X 32 X 9	1
18	0760 324771	WELLENDICHTRING 32X47X7 BSL	SHAFT SEAL RING 32X47X7 BSL	1
19	0770 250021	O-RING 25,00X2,00 SILICON	O-RING 25,00X2,00 SILICON	1
020	580.33.029.014	KETTENRAD 14 Z	ENGINE SPROCKET 14 T	X
020	580.33.029.015	KETTENRAD 15 Z	ENGINE SPROCKET 15 T	X
020	580.33.029.016	KETTENRAD 16 Z	ENGINE SPROCKET 16 T	X
020	580.33.029.017	KETTENRAD 17 Z	ENGINE SPROCKET 17 T	X
20	580.33.029.115	KETTENRAD 15 Z GEDÄMPFT	ENGINE SPROCKET 15 T DAMPED	X
20	580.33.029.116	KETTENRAD 16 Z GEDÄMPFT	ENGINE SPROCKET 16 T DAMPED	X
20	580.33.029.117	KETTENRAD 17 Z GEDÄMPFT	ENGINE SPROCKET 17 T DAMPED	X
21	0770 220010	O-RING 22,00X1,00 NBR 70	O-RING 22,00X1,00 NBR 70	1
22*	590.33.034.044	SCHRAUBE+TELLERFEDER	SCREW+SPRING WASHER	1
24	0125 100003	UNTERLEGSCHIEBE DIN0125-A10,5 NUR FÜR 640 DUKE	WASHER DIN0125-A10,5 ONLY FOR 640 DUKE	1
25	546.33.014.100	DISTANZBÜCHSE 12MM NUR FÜR 640 DUKE	SPACER BUSHING 12 MM ONLY FOR 640 DUKE	1



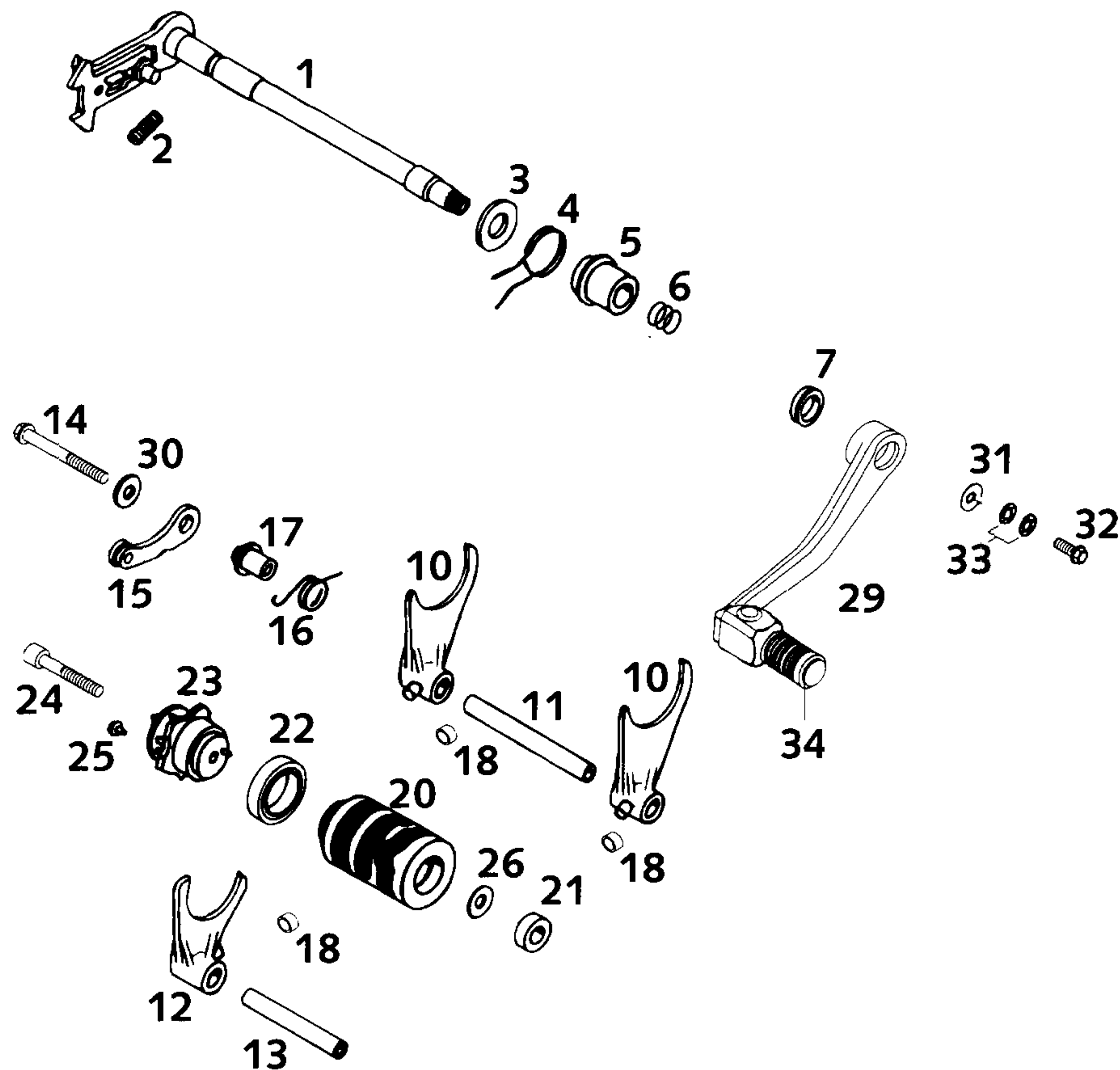

FIG	TEILNR/PARTNR	BEZEICHNUNG	DESCRIPTION	QTY
1	583.34.005.044	SCHALTWELLE KPL. LC4'94	SHIFT SHAFT CPL. LC4'94	1
2	565.34.013.100	SPANNFEDER 0,8MM	SPANNER SPRING 0,8MM	1
3	580.34.010.000	STAHLSCHEIBE 14 X 28 X 2	STEEL WASHER 14 X 28 X 2	1
4	580.34.014.000	RÜCKHOLFEDER	RETURN SPRING	1
5	583.34.020.000	FEDERHÜLSE	SPRING SLEEVE	1
6	0770 125020	O-RING 12,50X2,00 NBR 70	O-RING 12,50X2,00 NBR 70	3
7	580.33.027.000	V-DICHTRING V-14-A	V-SEAL RING V-14-A	1
10	580.34.002.300	SCHALTGABEL 1./4.U.2.GANG '98	SHIFT FORK 1ST/4TH+2ND GEAR'98	2
11	580.34.004.000	SCHALTSCHIENE 1./4. U. 2.GANG	SHIFT RAIL 1ST/4TH + 2ND GEAR	1
12	580.34.001.300	SCHALTGABEL 3./5. GANG '98	SHIFT FORK 3RD/5TH GEAR '98	1
13	580.34.003.000	SCHALTSCHIENE 3./5. GANG	SHIFT RAIL 3RD/5TH GEAR	1
14	0015 060653	SK.BUNDSCHRAUBE M 6X65 SW=8	HH COLLAR SCREW M 6X65 WS=8	1
15	583.34.024.044	ARRETIERHEBEL KPL. '94	LOCKING LEVER CPL. '94	1
16	580.34.023.500	ARRETIERHEBELFEDER	SPRING	1
17	583.34.017.000	ARRETIERFEDERHÜLSE	SPRING SLEEVE	1
18	503.34.018.100	SCHALTROLLE 6X8X5,2 '98	SHIFTING ROLLER 6X8X5,2 '98	3
20	583.34.012.000	SCHALTWALZE STAHL	SHIFT ROLLER STEEL	1
21	0625 006087	RILLENKUGELLAGER 608 2RS C3	GROOVED BALL BEAR. 608 2RS C3	1
22	0625 618050	RILLENKUGELLAGER 61805 C3	BALL BEARING 61805 C3	1
23	584.34.015.044	SCHALTARRETIERUNG KPL. LC4 '98	SHIFT LOCATING DRUM CPL. '98	1
24	0912 060404	ISK.SCHRAUBE DIN0912-M 6X40	AH SCREW DIN0912-M 6X40	1
25	580.34.016.500	SCHALTKNOPF	SHIFT BUTTON	1
26	510.06.097.000	SCHEIBE 6,4X21,8X1MM	WASHER 6,4X21,8X1MM	1
29	584.34.031.144	SCHALTHEBEL KPL. LC4,COMP. '98	SHIFT LEVER CPL. LC4,COMP. '98	1
30	502.32.050.000	STAHLSCHEIBE 6,2 X 18 X 2	WASHER 6,2 X 18 X 2	1
31*	502.32.050.001	STAHLSCHEIBE 6X17X3	STEEL WASHER 6X17X3	1
32	0015 060163	SK.BUNDSCHRAUBE M 6X16 SW=8	HH COLLAR SCREW M 6X16 WS=8	1
33	502.33.041.000	NORDLOCK SCHEIBEN M6 (PAAR)	PAIR OF WASHERS M6 NORDLOCK	1
34	362.05.018.000	TRITTGUMMI	RUBBER	1

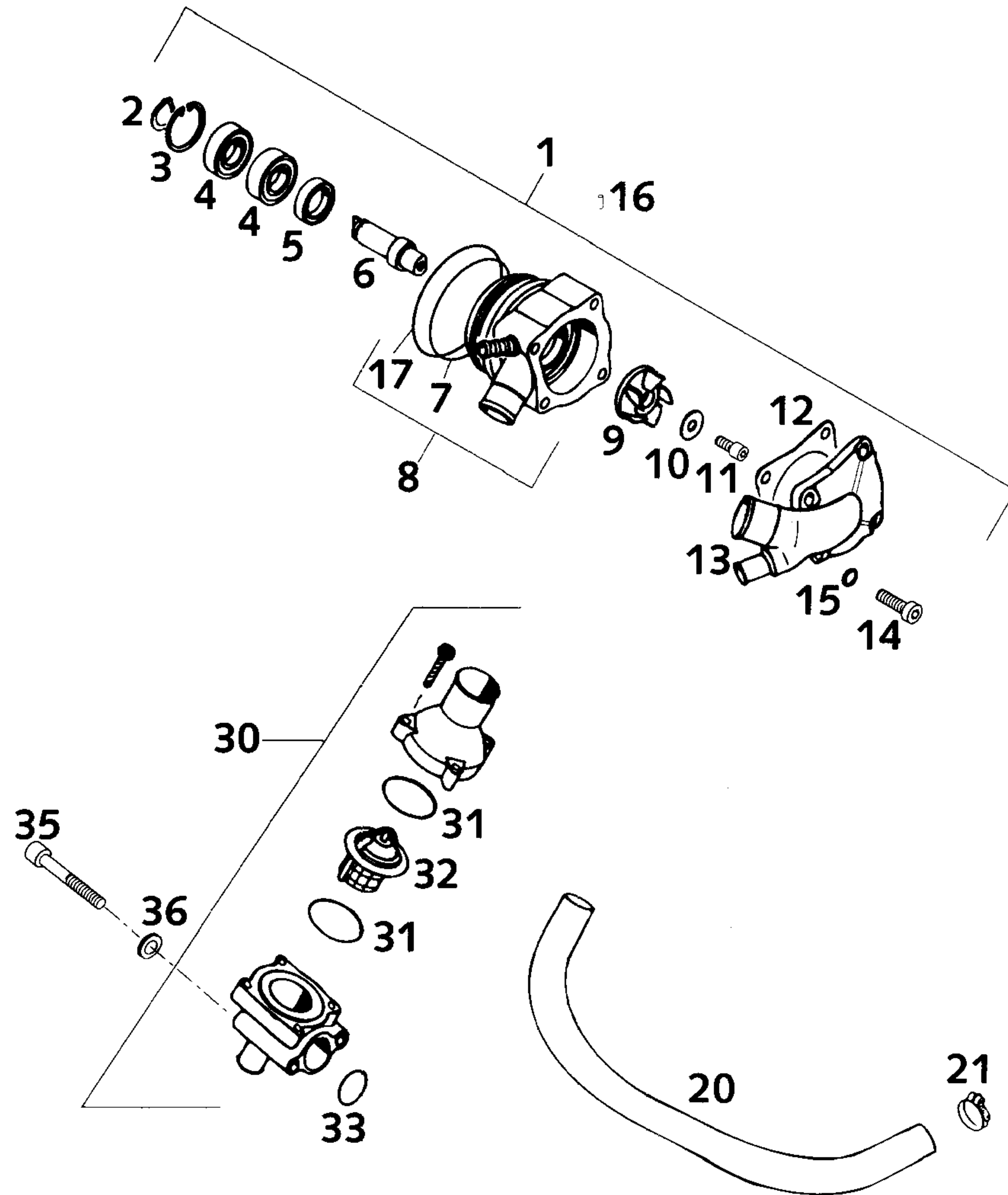

FIG	TEILNR/PARTNR	BEZEICHNUNG	DESCRIPTION	QTY
1	583.35.050.044	WASSERPUMPE MECHANISCH KPL.'94	WATER PUMP MECHANIC CPL.'94	1
2	0471 120010	SICHERUNGSRING DIN0471-12X1	CIRCLIP DIN0471-12X1	1
3	0472 280120	SICHERUNGSRING DIN0472 28X1,2	CIRCLIP DIN0472-28X1,2	1
4	0625 060016	RILLENKUGELLAGER 6001.2RSR C3	GROOVED BALL BEARING 6001.2RSR	2
5	0760 152472	WELLENDICHTRING 15X24X7 A-DUO	SHAFT SEAL RING 15X24X7	1
6	544.35.010.000	WASSERPUMPENWELLE	WATER PUMP SHAFT	1
7	0770 047015	O-RING 47,00X1,50 NBR 70	O-RING 47,00X1,50 NBR 70	1
8	580.35.002.644	WASSERPUMPENGEHÄUSE KPL. 4T'00	WATER PUMP CASE CPL. 4T '00	1
9	565.35.005.300	WASSERPUMPENRAD	WATER PUMP WHEEL	1
10	0021 050003	SCHEIBE DIN9021-A 5,3	WASHER DIN9021-A 5,3	1
11	0912 050123	ISK.SCHRAUBE DIN0912-M 5X12	AH SCREW DIN0912-M 5X12	1
12	565.35.003.300	PUMPENDECKELDICHTUNG	WATER PUMP COVER GASKET	1
13	583.35.001.244	WASSERPUMPENDECKEL LC4 '99	WATER PUMP COVER LC4 '99	1
14	0984 060203	ZYL.SCHRAUBE DIN6912-M 6X20	AH SCREW DIN6912-M 6X20	4
15	0603 061001	CU-DICHRING DIN7603- 6X10X1	CU-SEAL RING DIN7603- 6X10X1	4
16	0402 025580	NADELROLLE DIN5402 NRB 2,5X5,8	NEEDLEROLL.DIN5402 NRB 2,5X5,8	X
17	0770 049025	O-RING 49,00X2,50 NBR	O-RING 49,00X2,50 NBR	1
20	583.35.025.001	KÜHLERGEWEBESCHLAUCH 12 X 3	RADIATOR HOSE(REENFORCED)12X3	1
21	583.35.099.000	SCHLAUCHBINDER GEMI 10-16	HOSE CLAMP GEMI 10-16	2
30	583.35.013.044	THERMOSTAT KPL. 70 GRAD LC4'94	THERMOSTAT CPL. 70 DG LC4'94	1
31	0770 320020	O-RING 32,00X2,00	O-RING 32,00X2,00	2
32	583.35.017.000	THERMOSTAT 70 GRAD '94	THERMOSTAT 70 DEGREES '94	1
33	0770 021020	O-RING 21,00X2,00 NBR70	O-RING 21,00X2,00 NBR70	1
35	0912 060453	ISK.SCHRAUBE DIN0912-M 6X45	AH SCREW DIN0912-M 6X45	2
36	0125 060003	UNTERLEGSCHLEIBE DIN0125-A 6,4	WASHER DIN0125-A 6,4	2

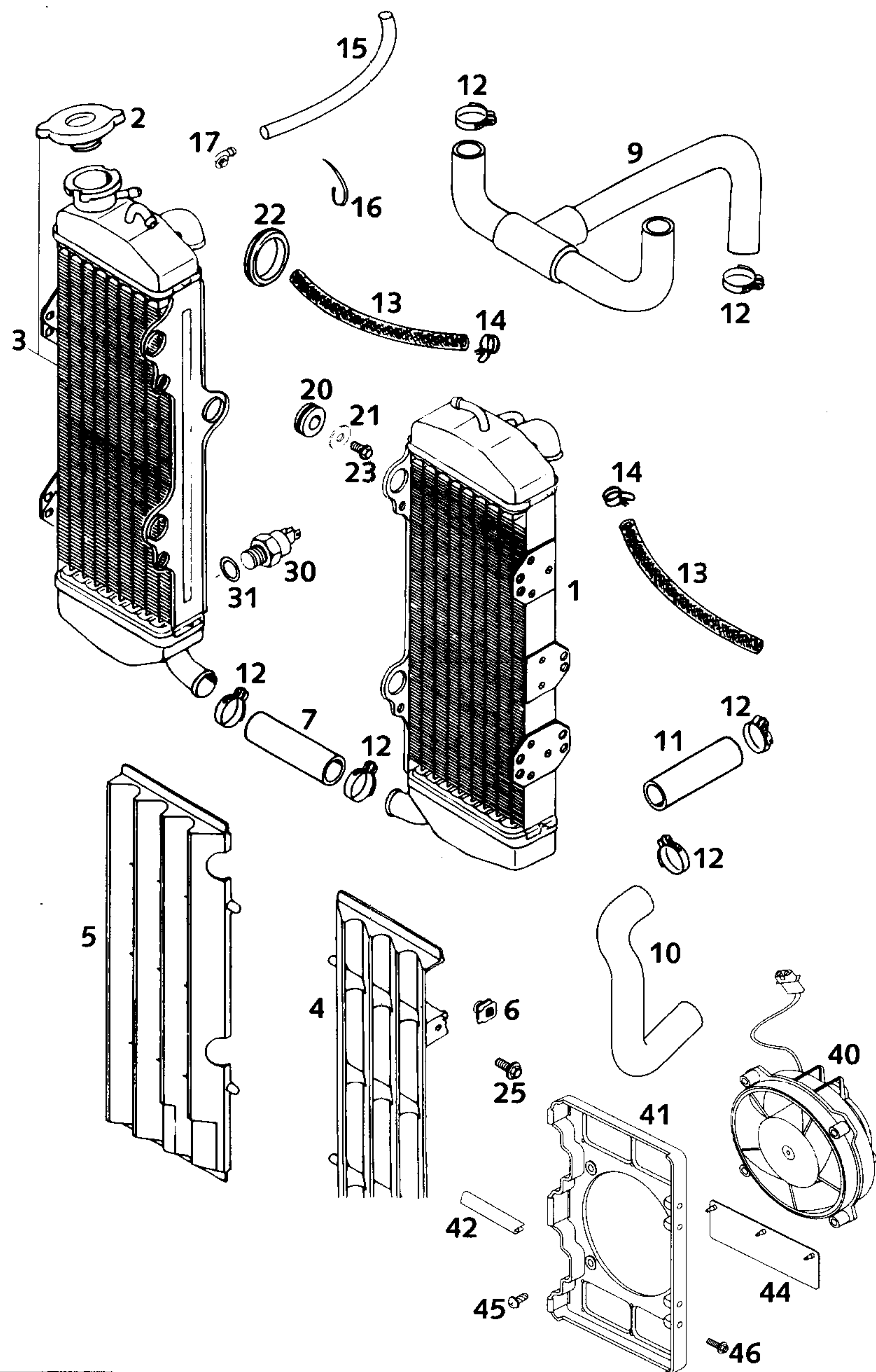
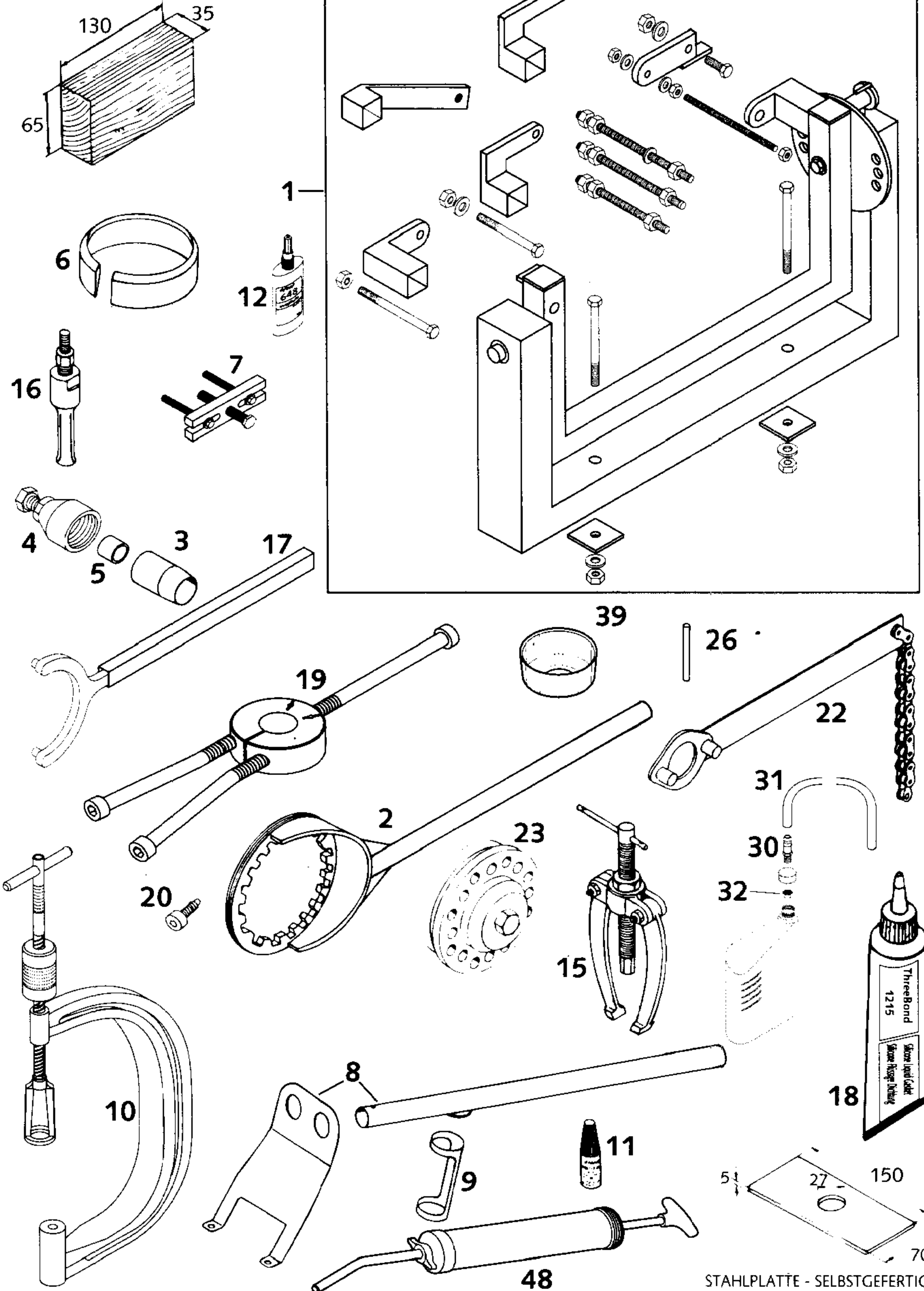

FIG	TEILNR/PARTNR	BEZEICHNUNG	DESCRIPTION	QTY
1	583.35.008.000	KÜHLER LINKS (45246) LC4'94	RADIATOR L/S (45246) LC4'94	1
2	580.35.016.000	KÜHLERVERSCHLUSS KLEIN 1,4 BAR	RADIATOR CAP SMALL 1,4 BAR	1
3	579.35.008.000	KÜHLER RECHTS (45335) LC4 '99	RADIATOR R/S (45335) LC4 '99	1
4	580.35.034.000	KÜHLERSCHUTZ LINKS SCHWARZ	RADIATOR PROTECTOR L/S BLACK	1
4	580.35.034.100	KÜHLERSCHUTZ LI. FARBLOS '96	RADIATOR PROTECT. L/S WHITE'96	X
5	580.35.134.000	KÜHLERSCHUTZ RECHTS SCHWARZ	RADIATOR PROTECTOR R/S BLACK	1
5	580.35.134.100	KÜHLERSCHUTZ RE. FARBLOS '96	RADIATOR PROTECT. R/S WHITE'96	X
6	502.35.033.300	KLIPS-MUTTERNHALTER M6 KP142	SNAP-NUT HOLDER M6 KP142	4
7	565.35.025.001	KÜHLERSCHLAUCH 18X25 PER MET.	RADIATOR HOSE 18X25 PER METER	0,10
9	583.35.026.000	FORMSCHLAUCH LC4'94	PREFORMED HOSE LC4'94	1
10	584.35.025.700	FORMSCHLAUCH 18X25 PUMPE-ZYL.	PREFORMED HOSE 18X25 PUMP-CYL.	1
11	583.35.024.001	KÜHLERSCHLAUCH 20 X 26	RADIATOR HOSE 20 X 26	0,11
12	100.01.020.000	SCHLAUCHKLEMME GEMI 16/27	HOSE CLAMP GEMI 16/27	9
13	544.35.024.001	ND-SCHLAUCH ID 7,5 PER METER	HOSE ID 7,5 PER METER	0,52
14	502.31.005.000	YDNAC - KLAMMER 10119	HOSE CLAMP YDNAC 10119	4
15	550.07.016.001	SCHLAUCH 7X10 PER METER	PVC-HOSE 7X10 PER METER	0,31
16	440.11.076.200	KABELBAND 200MM	CABLE TIE 200MM	X
17	503.03.089.000	WINKELSTÜCK '97	ANGEL PIECE '97	1
20	410.01.052.000	KABELTÜLLE D=12MM	RUBBER SLEEVE D=12MM	6
21	0021 060003	SCHEIBE DIN9021-A 6,4	WASHER DIN9021-A 6,4	6
22	546.35.022.000	TÜLLE-STEUERKOPF	SLEEVE FOR STEERING HEAD	2
23	0015 060123	SK.BUNDSCHRAUBE M 6X12 SW=8	HH COLLAR SCREW M 6X12 WS=8	6
25	0014 060153	SK.BUNDSCHRAUBE M 6X15 SW=8	HH COLLAR SCREW M 6X15 WS=8	2
30	580.35.045.000	THERMOSCHALTER 80-85 GRAD '94	THERMOSWITCH 80-85 DG '94	1
31	0603 142015	ALU-DICHTRG. DIN7603-14X20X1,5	ALU SEALRING DIN7603-14X20X1,5	1
40	584.35.041.000	LÜFTER KPL. 12V LC4 2000	FAN CPL. 12V LC4 2000	1
41	584.35.044.000	LÜFTERHAUBE LC4 2000	FAN CAP LC4 2000	1
42	583.12.085.100	DICHTUNGSPROFIL F. ABDECKUNG	EDGE PROTECTOR FOR COVER	0,22
44	584.35.044.050	LÜFTERKLAPPE GUMMI LC4 2000	FAN FLAP RUBBER LC4 2000	2
45	0081 500181	EJOT PT SCHRAUBE KA50X18WN1411	EJOT PT SCREW KA 50X18 WN1411	4
46	0017 060203	SONDERSCHRAUBE T60 6X20	SPECIAL SCREW T60 6X20	2

HOLZKLOTZ - SELBSTGEFERTIGT
WOODEN BLOCK - HOME MADE



01-584.29.0

STAHLPLATTE - SELBSTGEFERTIGT
STEEL PLATE - HOME MADE

FIG	TEILNR/PARTNR	BEZEICHNUNG	DESCRIPTION	QTY
1	560.12.001.000	UNIVERSALMONTAGEBOCK '96	UNIVERSAL MOUNTING RACK '96	1
2	583.29.003.000	KUPPLUNGSHALTER D=160MM LC4'94	CLUTCH HOLDER D=160MM LC4'94	1
3	580.12.005.025	MONTAGEHÜLSE D=25MM FÜR KURBELW.SIMMERRING LINKS	MOUNTING SLEEVE D=25MM FOR CRANKSHAFT SEAL L/S	1
4	584.29.009.000	SCHWUNGRADABZIEHER	MAGNETO EXTRACTOR	1
5	584.29.031.000	SCHUTZKAPPE F. KURBELWELLE M16	PROTECTOR CAP F. CRANKSHAFT M16	1
6	580.12.015.101	KOLBEN-MONTAGERING D=101MM 620/640 LC4	PISTON RING COMPRESSOR D=101MM 620/640 LC4	1
6	580.12.015.089	KOLBEN-MONTAGERING D=89MM 350/400 LC4	PISTON RING COMPRESSOR D=89MM 350/400 LC4	1
7*	590.29.021.000	ABZIEHER PRIM. RAD-KUPP. MITN. F. PRIMÄRRAD U. KUPPL. MITNEHMER	EXTRACT. PRIM. GEAR - INNER CLUTCH F. PRIM. GEAR D. INNER CLUTCH HUB	1
8	580.12.019.000	VENTIL-MONTAGEVORRICHTUNG	VALVE INSTALLATION KIT	1
9	6 276 470	VENTILFEDER-SPANNEINSATZ	PUSH INSERT	1
10*	590.29.019.000	VENTILFEDERHEBER	VALVE SPRING LEVER	1
11	6 899 785	LOCTITE 243 BLAU 6CCM	LOCTITE 243 BLUE 6CCM	X
12	584.29.059.000	LOCTITE 648 GRÜN 20ML	LOCTITE 648 GREEN 20ML	X
15	151.12.017.000	LAGERAUSZIEHER	BEARING EXTRACTOR	1
16	151.12.018.000	EINSATZ 12-16 MM	INTERN. BEAR. PULLER 12-16 MM	1
16	151.12.018.100	EINSATZ 18-23 MM	INTERN. BEAR. PULLER 18-23 MM	1
17	584.29.012.000	HALTESCHLÜSSEL F. SCHWUNGRAD	HOLDING WRENCH FOR WHEEL	1
18	309098	SILIKONDICHTMASSE THREE-BOND	SILICON GASKET THREE-BOND	1
19*	584.29.037.043	MONTAGEW. F. LAGERINNENR. NJ 207	MOUNTING TOOL F. BEARING NJ 207	1
19*	584.29.037.040	MONTAGEW. F. LAGERINNENR. NJ 306	MOUNTING TOOL F. BEARING NJ 306	1
20	580.30.080.000	FIXIERSCHRAUBE M8	LOCATING SCREW M8	1
22	510.12.012.000	HALTESCHLÜSSEL F. KETTENRITZEL	HOLDING SPANNER FOR SPROCKET	1
23	546.29.027.000	NIETWERKZEUG FÜR KUPPLUNG	RIVETTING TOOL FOR CLUTCH	1
26	580.29.026.007	GRENZLEHRDORN F. VENTILFÜHRUNG D=7,05MM	LIMIT PLUG GAUGE F. VALVE GUIDE D=7,05MM	1
30	590.30.022.000	ENTLÜFTUNGSSTUTZEN M8 SW=10'99	BLEEDER FLANGE M8 WS=10 '99	1
31	310.07.107.001	PVC-SCHLAUCH 6X9 MM PER METER	PVC-HOSE 6X9 MM PER METER	0,3
32	0934 080003	SK. MUTTER DIN0934-M 8	HEXAGON NUT DIN0934-M 8	1
39	583.29.039.000	SCHLÜSSEL FÜR SCHRAUBFILTER	WRENCH SCREW FILTER	1
48	584.29.048.000	SPRITZE F. RAHMENBRUSTROHR '99 ENTLÜFTEN FÜR RAHMENBRUSTROHR	INJEKTION FOR FRONT PIPE '99 DEAERATE FOR FRONT PIPE	1

* = NEUTEIL / NEW PART

X = NACH BEDARF / AS REQUIRED

TECHNISCHE DATEN – MOTOR 400/640 LC4-E, 640 LC4 ADVENTURE, 640 DUKE 2001

Motor	400 LC4-E	640 LC4-E, 640 LC4 Adventure, 640 Duke
Bauart	1-Zylinder 4-Takt Otto-Motor mit Ausgleichswelle, flüssigkeitsgekühlt, mit E-Starter	
Hubraum	398 cm ³	624,6 cm ³
Bohrung/Hub	89 / 64 mm	101 / 78 mm
Verdichtung	10,8 : 1	11,0 : 1
Kraftstoff	bleifreier Superkraftstoff mit mindestens ROZ 95	
Steuerung	4 Ventile über Kipphebel u. 1 Nockenwelle gesteuert, Antrieb der Nockenwelle mit Einfachkette	
Nockenwelle	249/1	
Ventildurchmesser	Einlaß: 36 mm Auslaß: 30 mm	
Ventilspiel kalt	Einlaß: 0,20 mm Auslaß: 0,20 mm	Einlaß: 0,15 mm Auslaß: 0,15 mm
Kurbelwellenlagerung	2 Zylinderrollenlager	
Pleuellager	Nadellager	
Kolbenbolzenlager	Bronzebüchse	
Kolben	Leichtmetall – gegossen/geschmiedet	
Kolbenringe	1 Kompressionsring, 1 Minutenring, 1 Ölabstreifring	
Motorschmierung	2 Eatonpumpen	
Motoröl	siehe Tabelle	
Füllmenge Motoröl	2,1 Liter einschließlich Rahmen	
Primärtrieb	gerade verzahnte Stirnräder 30:81 Z	
Kupplung	Mehrscheibenkupplung im Ölbad	
Getriebe	5-Gang klauengeschaltet	
Zündanlage	kontaktlos gesteuerte DC- CDI Zündanlage mit digitaler Zündverstellung, Typ KOKUSAN	
Zündzeitpunkt	Verstellung bis max. 38° v. OT bei 6000/min	
Generator	12V 200W	
Zündkerze	NGK DPR8 EA9	
Elektrodenabstand	0,9 mm	
Kühlung	Flüssigkeitskühlung, permanente Umwälzung der Kühlflüssigkeit durch Wasserpumpe	
Kühlflüssigkeit	1 Liter, Mischungsverhältnis 40% Frostschutz, 60% Wasser, mindestens -25° C	
Starthilfe	Elektrostarter und Kickstarter	

EINBAUSPIELE, VERSCHLEISSGRENZEN

Kurbelwelle	Axialspiel	0,03 - 0,12 mm
	Kurbelzapfenschlag	max. 0,08 mm
Pleuellager	Radialspiel	max. 0,05 mm
	Axialspiel	max. 1,10 mm
Zylinder 400	Bohrung Durchmesser	max. 89,04mm
Zylinder 640	Bohrung Durchmesser	max. 101,04mm
Kolben geschmiedet	Einbauspiel	max. 0,12 mm
Kolben gegossen	Einbauspiel	max. 0,05 mm
Kolbenringe Stoßspiel	Kompressionsringe	max. 0,80 mm
	Ölabstreifring	max. 1,00 mm
Ventile	Dichtsitzbreite Einlaß	max. 1,50 mm
	Dichtsitzbreite Auslaß	max. 2,00 mm
	Ventilteller Schlag	max. 0,05 mm
	Ventilführung Durchmesser	max. 7,05 mm
Ölpumpen	Spiel Außenrotor - Gehäuse	max. 0,20 mm
	Spitzenspiel Außen - Innenrotor	max. 0,20 mm
Bypaßventil	Druckfeder Mindestlänge	25 mm
Kupplung	Länge Kupplungsfedern	min. 34,5 mm (neu 37 mm)
	Mindeststärke organisch	min. 2,5 mm
Nockenwelle	Lagerzapfendurchmesser (Nadellager)	min. 19,97 mm
Getriebewellen	Axialspiel	0,1 - 0,4 mm

ANZUGSDREHMOMENTE - MOTOR

Sechskantmutter Primärrad	M20x1,5	Loctite 243 + 170 Nm
Sechskantmutter Schwungrad	M16x1,25 links	80° C + 150 Nm
Sechskantmutter für Kupplungsmittnehmer	M18x1,5	Loctite 648 + 80 Nm
Kickstarter-Anschlagschraube	M12x1,5	50 Nm
Innensechskantschrauben der Freilaufnabe	M6x12/M6x12,5	Loctite 648 + 18 Nm
Innensechskantschrauben der Ölpumpen	M6	Loctite 243 + 8 Nm
Sechskantschraube Nockenwellenrad	M10	Loctite 243 + 35 Nm
Schrauben Zylinderkopf-Oberteil	M6x25/M6x65/M6x70 (8.8)	8 Nm
Schrauben Zylinderkopf-Oberteil	M6x50/M6x55 (12.9)	20 Nm
Zylinderkopfschrauben	M10	50 Nm
Bundmuttern am Zylinderfuß	M10	40 Nm
Sechskantschraube Kettenrad	M10	Loctite 243 + 40 Nm
Ölablaßschraube	M22x1,5	30 Nm
Magnetschraube	M12x1,5	20 Nm
Verschußschraube Bypaßventil	M12x1,5	20 Nm
Hohlschrauben Ölleitungen	M8x1	10 Nm
Hohlschrauben Ölleitungen	M10x1	15 Nm
Düsenschraube Kupplungsdeckel	M8	10 Nm
Verschußschraube Steuerkettenspanner	M12x1,5	20 Nm
Kontermutter Ventileinstellschrauben	M7x0,75	20 Nm
Kurbelwellen- Blockierschraube	M8	25 Nm
Motorbefestigungsschrauben	M8	40 Nm
Motorbefestigungsschrauben	M10	70 Nm

GETRIEBEÜBERSETZUNG

Primär- übersetzung	Getriebeübersetzung	Orig. Übersetzung Hinterrad	Lieferbare Kettenritzel	Lieferbare Kettenräder hinten
30:81	1.Gang 14:35			38 Z
	2.Gang 15:24	15:45	15 Z	40 Z für Kette
	3.Gang 18:21	16:42	16 Z für Kette	42 Z $\frac{5}{8} \times \frac{1}{4}$ "
	4.Gang 20:19	17:38	17 Z $\frac{5}{8} \times \frac{1}{4}$ "	45 Z
	5.Gang 22:18	17:42		48 Z

API: SG, SH

TEMPERATUR

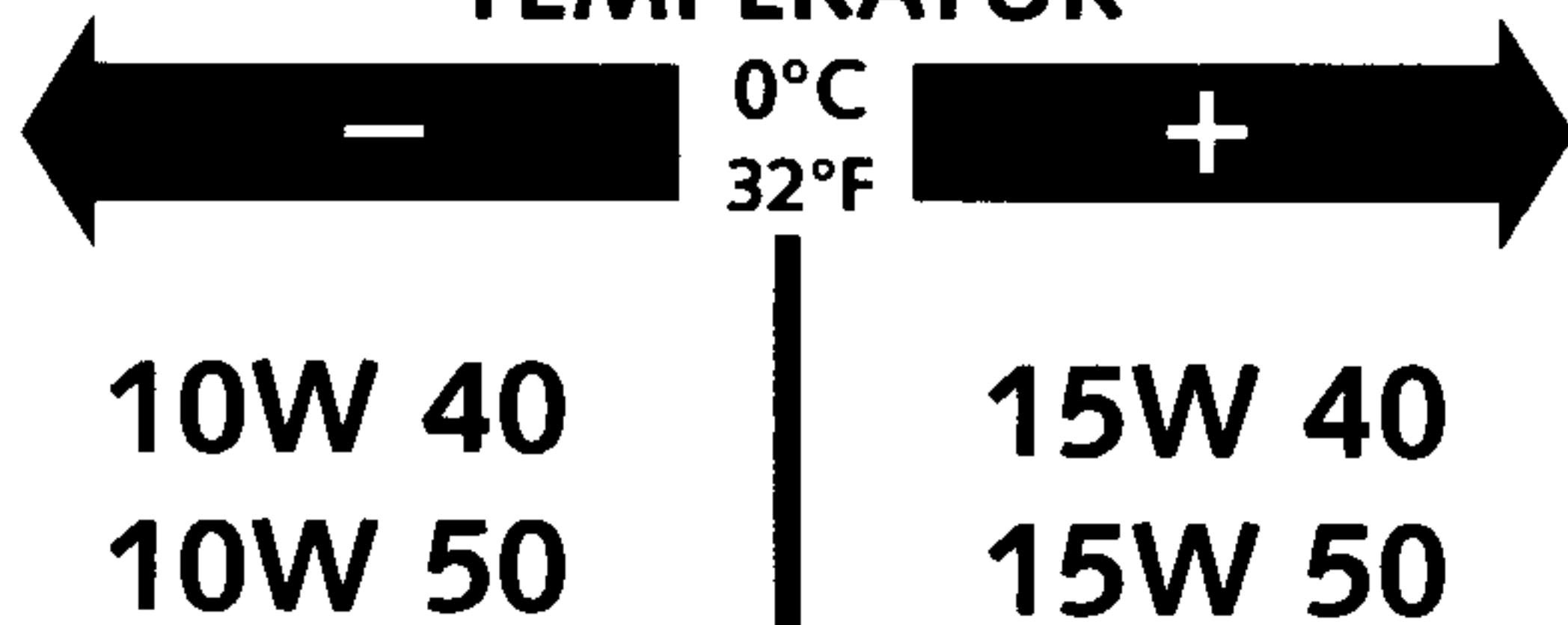

Motoröl

Verwenden Sie nur vollsynthetische Markenöle (Shell Advance Ultra 4), welche die Qualitätsanforderungen der API-Klassen SG oder SH (Angaben auf dem Behälter) erfüllen oder übertreffen.

! VORSICHT !

ZU WENIG MOTORÖL ODER QUALITATIV MINDERWERTIGES ÖL FÜHRT ZU VORZEITIGEM VERSCHLEISS DES MOTORS.

VERGASER - GRUNDEINSTELLUNG

	400 LC4-E 25 kW	400 LC4-E 31 kW	400 LC4-E USA
Vergasertyp	PHM 38 ND	PHM 38 ND	BST40-225
Regulierungsnummer	100197	100197	090298
Hauptdüse	130	130	142,5
Nadeldüse	AR 264	AR 264	689 X-6
Leerlaufdüse	50	50	45
Düsennadel	K 23	K 23	6G5
Nadelposition	2. von oben	2. von oben	3. von oben
Gemischreg.Schr. offen	1,5 Umdr.	1,5 Umdr.	2,25 Umdr.
Gasschieber	50/1	50/1	-
Startdüse	45(50,55)	45(50,55)	-
Drosselung	Schieberanschlag 51 mm	-	-

VERGASER - GRUNDEINSTELLUNG

	640 LC4-E, Adventure 25 kW	640 LC4-E, Adventure 36 kW	640 Duke 40 kW
Vergasertyp	BST40-225	BST40-225	BST40-225
Regulierungsnummer	080298	090298	100299
Hauptdüse	142,5	142,5	145
Nadeldüse	689 X-6	689 X-6	689 X-6
Leerlaufdüse	45	45	45
Düsennadel	6G5	6G5	6G5
Nadelposition	3. von oben	3. von oben	3. von oben
Gemischreg.Schr. offen	2,25	2,25	2,25
Gasschieber	-	-	-
Startdüse	-	-	-
Drosselung	Schieberanschlag 17 mm	-	-

TECHNICAL DATA - ENGINE 400/640 LC4-E, 640 LC4 ADVENTURE, 640 DUKE 2001

Type	400 LC4-E	640 LC4-E, 640 LC4 Adventure, 640 Duke
Design	Liquid-cooled single cylinder 4-stroke engine with balancer shaft and electric starter	
Displacement	398 ccm	624,6 ccm
Bore / Stroke	89 / 64 mm	101 / 78 mm
Ratio	10,8 : 1	11,0 : 1
Fuel	unleaded premium gasoline with a least RON 95	
Valve timing	4 valves over rocker arm and 1 overhead camshaft, camshaft drive through single chain	
Camshaft	249/1	
Valve diameter	Intake: 36 mm Exhaust: 30 mm	
Valve clearance cold	Intake: 0.20 mm Exhaust: 0.20 mm	Intake: 0.15 mm Exhaust: 0.15 mm
Crank shaft bearing	2 cylinder roller bearing	
Connecting rod bearing	needle bearing	
Top end bearing	bronze bushing	
Piston	forged/cast aluminium alloy	
Piston rings	1 compression ring, 1 taper face ring, 1 oil scraper ring	
Engine lubrication	2 Eaton-Oilpumps	
Quantity of engine oil	see table	
Engine oil	2.1 liters including frame	
Primary ratio	straight geared spur wheels 30 : 81 teeth	
Clutch	multi disc clutch in oil bath	
Transmission	5-speed claw shifted	
Ignition system	contactless DC- CDI ignition with digital advanced system type KOKUSAN	
Ignition timing	adjustment to max. 38° BTDC at 6000 rpm	
Generator	12V 200W	
Spark plug	NGK DPR8 EA9	
Spark plug gap	0.9 mm	
Cooling system	liquid cooled, permanent rotation of cooling liquid through mechanic driven water pump	
Cooling liquid	1 liter, 40% antifreeze, 60% water, at least -25° C (-13° F)	
Starting equipment	electric starter, kick starter	

ASSEMBLY CLEARANCE, WEAR LIMIT

Crank shaft	axial play	.003 - 0.12 mm
	run out of crank stud	max. 0.08 mm
Connecting rod bearing	radial play	max. 0.05 mm
	axial play	max. 1.10 mm
Cylinder 400	bore	max. 89.04 mm
Cylinder 640	bore	max. 101.04 mm
Piston forged	assembly clearance	max. 0.12 mm
Piston cast	assembly clearance	max. 0.05 mm
Piston rings end gap	compression rings	max. 0.80 mm
	oil scraper ring	max. 1.00 mm
Valves	seat sealing intake	max. 1.50 mm
	seat sealing exhaust	max. 2.00 mm
	run out of valve heads	max. 0.05 mm
	valve guides diameter	max. 7.05 mm
Oil pumps	clearance outer rotor - housing	max. 0.20 mm
	clearance outer rotor - inner rotor	max. 0.20 mm
Bypaß valve	minimum spring length	25.00 mm
Clutch	Length of springs	min. 34.5 mm (new 37.00 mm)
	wear limit organic	min. 2.50 mm
Camshaft	diameter of bearing bolt (needle bearing)	min. 19.97 mm
Transmission shafts	axial play	.010 - 0.40 mm

TIGHTENING TORQUES - ENGINE

Hexagon nut at primary gear	M20x1.5	Loctite 243 + 170 Nm	(125 ft.lb)
Collar nut flywheel	M16x1.25 LH thread	80° C + 150 Nm	(132 ft.lb)
Hexagon nut for inner clutch hub	M18x1.5	Loctite 648 + 80 Nm	(60 ft.lb)
Kickstarter stop screw	M12x1.5	50 Nm	(35 ft.lb)
Allan head screws oil pump	M6	Loctite 243 + 8 Nm	(6 ft.lb)
Allan head screws freewheel hub	M6x12/M6x12.5	Loctite 648 + 18 Nm	(13 ft.lb)
Hexagon screw camshaft gear	M10	Loctite 243 + 35 Nm	(26 ft.lb)
Allan head screw cylinder head top sect.	M6x25/M6x65/M6x70 (8.8)	8 Nm	(6 ft.lb)
Allan head screw cylinder head top sect.	M6x50/M6x55 (12.9)	20 Nm	(15 ft.lb)
Cylinder head screws	M10	50 Nm	(37 ft.lb)
Collar nuts at cylinder base	M10	40 Nm	(30 ft.lb)
Hexagon screw chain sprocket	M10	Loctite 243 + 40 Nm	(30 ft.lb)
Oil drain plug	M22x1.5	30 Nm	(22 ft.lb)
Magnetic plug	M12x1.5	20 Nm	(15 ft.lb)
Plug bypass valve	M12x1.5	20 Nm	(15 ft.lb)
Hollow screws oil lines	M8x1	10 Nm	(7.4 ft.lb)
Hollow screws oil lines	M10x1	15 Nm	(11 ft.lb)
Jet screw clutch cover	M8	10 Nm	(7,4 ft.lb)
Screw plug timing-chain tensioner	M12x1.5	20 Nm	(15 ft.lb)
Counternuts valve adjusting screws	M7x0.75	20 Nm	(15 ft.lb)
Crankshaft locking bolt	M8	25 Nm	(19 ft.lb)
Engine mounting bolt	M8	40 Nm	(30 ft.lb)
Engine mounting bolt	M10	70 Nm	(50 ft.lb)

GEAR RATIOS

Primary ratio	Transmission	Original final drive ratio	Available chain drive sprockets	Available final drive sprockets
30:81	1st gear 14:35	15:45 16:42 17:38 17:42	15 t 16 t for chain 17 t 5/8 x 1/4"	38 t
	2nd gear 15:24			40 t for chain
	3rd gear 18:21			42 t 5/8 x 1/4"
	4th gear 20:19			45 t
	5th gear 22:18			48 t

API: SG, SH

TEMPERATURE

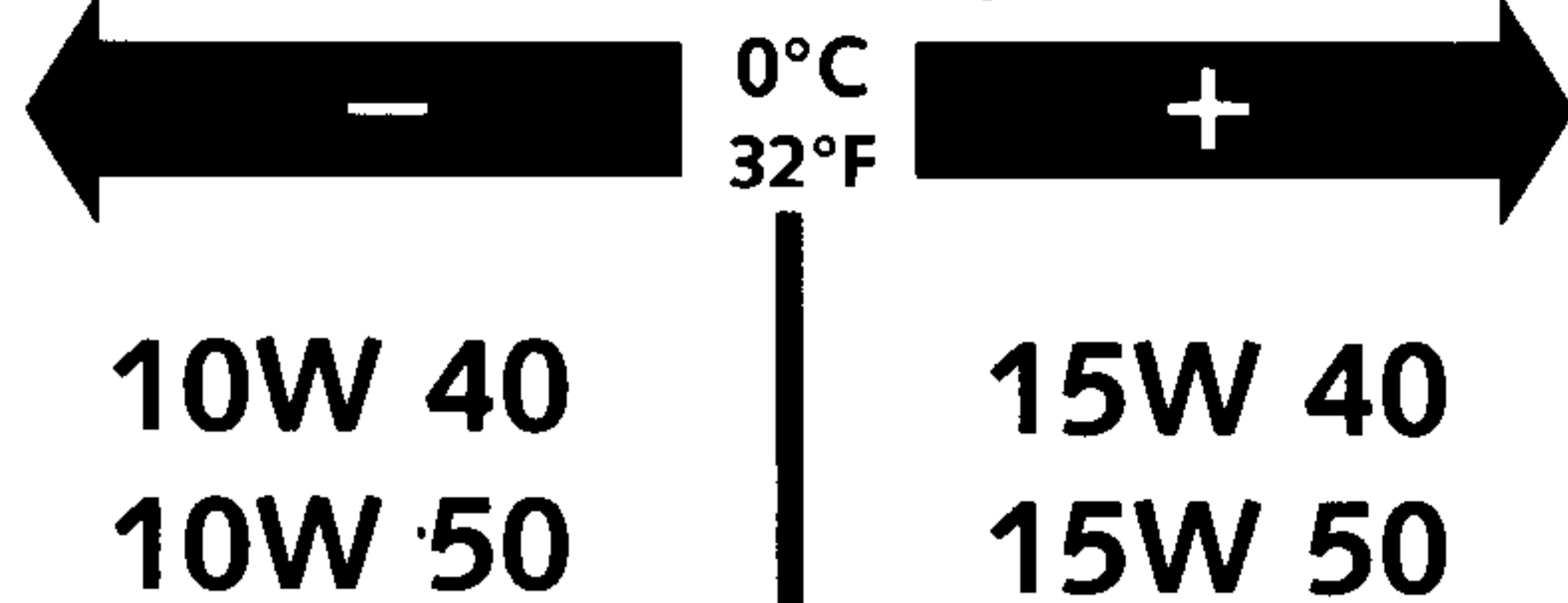

Engine oil

Use only oil brands, which meet quality requirements (Shell Advance Ultra 4) of API-classes SG or SH (informations on bottles) or higher.

! CAUTION !

POOR OIL QUALITY OR MINOR QUANTITY EFFECT EARLY ENGINE-WEAR.

BASIC CARBURETOR SETTING

	400 LC4-E 25 kW	400 LC4-E 31 kW	400 LC4-E USA
Type	PHM 38 ND	PHM 38 ND	BST40-225
Carb.-setting number	100197	100197	090298
Main jet	130	130	142,5
Needle jet	AR 264	AR 264	689 X-6
Idling jet	50	50	45
Jet needle	K 23	K 23	6G5
Needle clip pos. f. top	2. from top	2. from top	3. from top
Mixt. adj. screw open	1.5 turns	1,5 turns	2,25 turns
Throttle valve	50/1	50/1	-
Starting jet	45(50,55)	45(50,55)	-
Performance restrictor	slide stop 51mm	-	-

BASIC CARBURETOR SETTING

	640 LC4-E, Adventure 25 kW	640 LC4-E, Adventure 36 kW	640 Duke 40 kW
Type	BST40-225	BST40-225	BST40-225
Carb.-setting number	080298	090298	100299
Main jet	142,5	142,5	145
Needle jet	689 X-6	689 X-6	689 X-6
Idling jet	45	45	45
Jet needle	6G5	6G5	6G5
Needle clip pos. f. top	3. from top	3. from top	3. from top
Mixt. adj. screw open	2,25	2,25	2,25
Throttle valve	-	-	-
Starting jet	-	-	-
Performance restrictor	slide stop 17mm	-	-

! Die **KTM Sportmotorcycle AG** behält sich das Recht vor, Ausrüstung, technische Angaben, Farben, Materialien, Dienstleistungsangebote, Serviceleistungen und ähnliche Dinge ohne vorheriger Ankündigung und ohne Angabe von Gründen zu ändern bzw. ersatzlos zu streichen, sowie die Fertigung eines bestimmten Modells ohne vorherige Ankündigung einzustellen. Für Druckfehler übernehmen wir keine Haftung.

! **KTM Sportmotorcycle AG** reserves the right to modify any equipment, technical specifications, colors, materials, services offered and rendered, and the like so as to adapt them to local conditions without previous announcement and without giving reasons, or to cancel any of the above items without substituting them with others. It shall be acceptable to stop manufacturing a certain model without previous announcement. In the event of such modifications, please ask your local KTM dealer for information. We shall not be held liable for any printing errors.



KTM SPORTMOTORCYCLE AG
5230 Mattighofen
Austria
Internet: www.ktm.at

